

PLANAR

Mantis Series

The Planar® Mantis™ Series is a line of LED video walls engineered for the fast-paced demands of rental and staging. With fully tool-less installation and simplified handling, Mantis enables quick setup, teardown and maintenance—allowing crews with minimal LED experience to deploy large video walls with ease. A lightweight magnesium alloy construction provides strength and rigidity, helping maintain image integrity while improving handling. Designed to support real-world workflows, Mantis integrates seamlessly across venues and events. In addition to live production, it delivers reliable, camera-ready performance for on-camera applications, including broadcast and virtual production environments

1.5, 1.9 & 2.6mm pixel pitches

Tool-less set-up and maintenance

Lightweight, durable cabinet design

Simplified, single-operator handling

Optimized for live event and on-camera environments



Purpose-Built for Renting and Staging

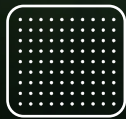

1.5, 1.9 & 2.6mm pixel pitches



Tool-less set-up and maintenance



Lightweight and durable cabinet design



Simplified, single-operator handling



Optimized for live event and on-camera environments

Professional-Grade Components

Engineered with professional-grade components intentionally selected for demanding rental and staging environments, Planar Mantis Series is built for durability, consistency and long-term reliability. From the cabinet structure to internal electronics, every element is designed for durability, consistency and long-term reliability. This focus on higher-quality materials and construction helps reduce wear over time, maintain alignment and support dependable performance across repeated installations, transport and use—ensuring Mantis performs reliably from one event to the next.

Integrated Magnets help hold cabinets in position during installation

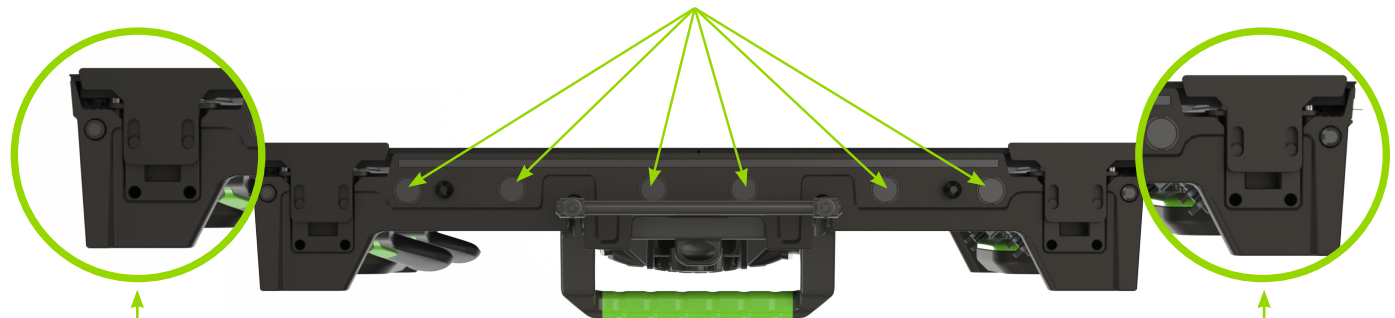

Crash Pin Cushions protect cabinets during magnetic alignment

Self-retracting Edge Protectors shield and prevent damage to outside LEDs during handling and installation. Once installed, the protectors retract into the cabinet for a clean visual appearance

Precision-Engineered Mechanics

Precision-engineered mechanics simplify every stage of installation and alignment. Clear tactile feedback helps adjustments feel confident, controlled and consistent.

Locking latches and clamps secure cabinets firmly in place, while clearly marked angle indicators simplify fine positioning. Green touchpoints help crews quickly identify key adjustment and locking locations during installation.

With secure, integrated mechanisms throughout the system design, Planar Mantis Series supports smooth, efficient deployment from set-up through final alignment.



Vertical Clamp secures bottom to top cabinet, enabling one-handed vertical cabinet attachment

Green components quickly and easily identify key touchpoints

Slide Latch (lock pins) secure cabinets side-by-side for one-handed side cabinet attachment and locking

Angle Adjustment allows for tool-less angle adjustments up to +10° in 2.5° increments

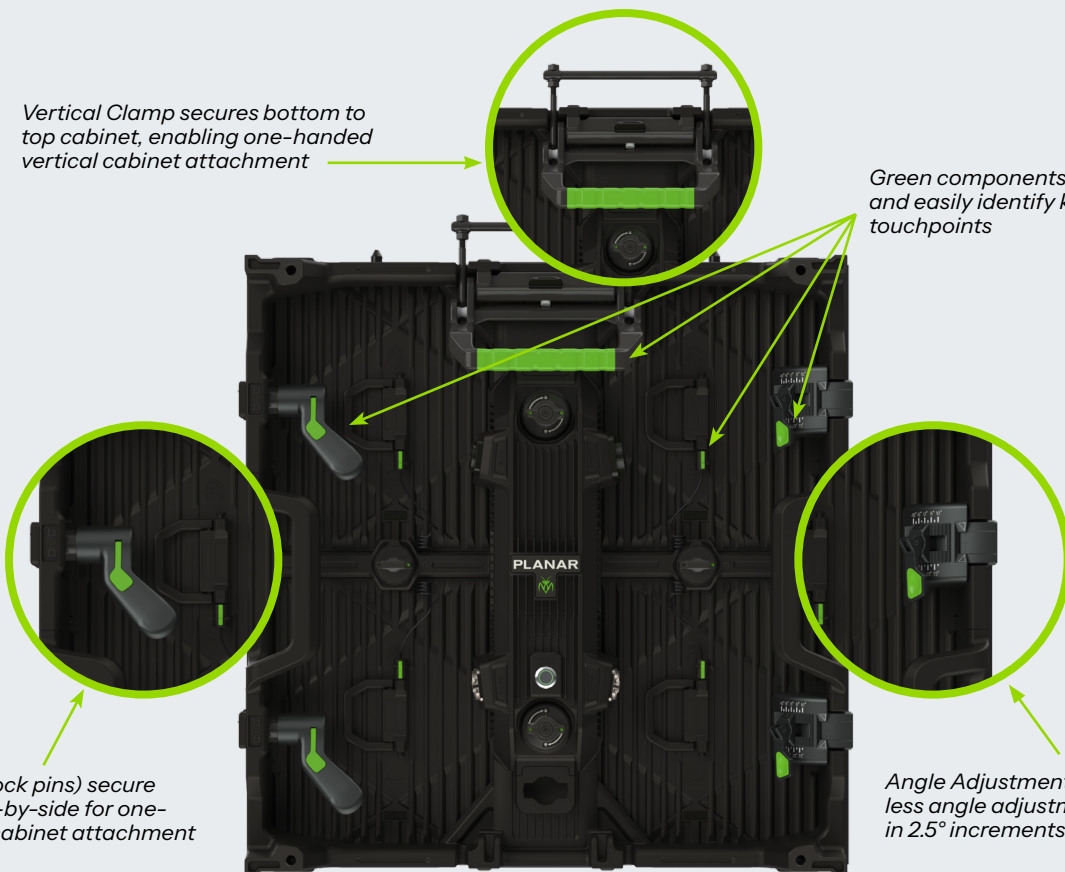

Fast, Efficient In-Field Service

Built for demanding rental and staging environments, Planar Mantis Series simplifies in-field service with fully tool-less access to modules and electronics. Intuitive quarter-turn mechanisms allow components to be quickly removed and replaced, reducing maintenance complexity and minimizing downtime.

The streamlined design enables crews of all experience levels to perform service tasks quickly and confidently, helping keep video walls operational and ready for the next deployment.



Quarter-turn locks simplify module and electronics replacement



Designed for easy handling without tools



Quickly replace and secure components

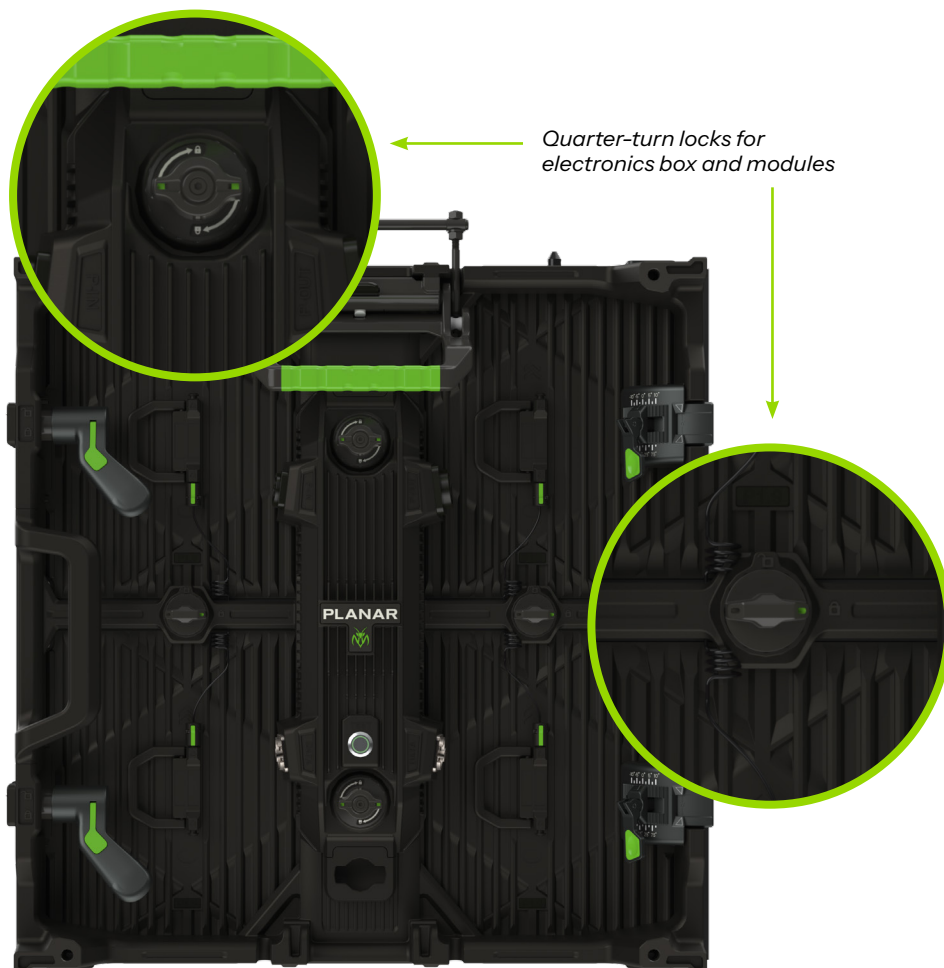

Quarter-turn locks for electronics box and modules



Electronics box



Serviceability Built-In

Planar Mantis Series is designed for long-term serviceability with an expanded range of replaceable components beyond standard field-replaceable units (FRUs).

In addition to standard service parts, critical components – including vertical clamps, magnets and plates, edge protectors, handle molding, lock pins, tethers, angle assemblies and gaskets – can all be individually replaced.

This expanded serviceability helps extend system lifespan, reduce replacement costs and maximize long-term return on investment.



Vertical Clamp



Magnets and Plates



Edge Protector



Handle Molding



Lock Pin (Side Latch)



Tether



Angle Assembly



Gasket



Optimized for On-Camera

Optimized for on-camera applications across a range of production environments, Planar Mantis Series supports broadcast, virtual production and live events that are streamed or recorded.

Designed to deliver consistent, stable image quality, the series performs reliably both in-person and through the lens—supporting a wide range of production and content capture needs. This allows Mantis to transition seamlessly between live events and on-camera production environments.

240Hz

HIGH FRAME RATE

Up to 240Hz frame rates for demanding on-camera use in multi-camera production environments.

1:8

LOW SCAN RATE

Scan rates as low as 1:8 help minimize visual artifacts and banding during on-camera

HORIZONTAL

SCAN DIRECTION

Horizontal scan direction helps support flicker-free, artifact-free performance across a wide range of camera types.

Transportation and Installation Solutions

Road Cases

Purpose-built for transport, storage and protection, Planar Mantis Series Road Cases support efficient handling across rental and staging workflows. A top-loading design simplifies packing and unloading, while configurations tailored to both 500×500 and 500×1000 cabinet sizes help streamline transport and deployment between venues and events.



Hanging Support

Engineered to simplify hanging installations in rental and staging environments, Mantis supports efficient top-down assembly. Cabinets support one-handed attachment through integrated top-latch engagement, while magnetic alignment along the cabinet edge helps guide cabinets into position and hold them during locking. This intuitive hanging capability streamlines installation, reduces handling complexity and supports faster deployment across a wide range of venues and events.

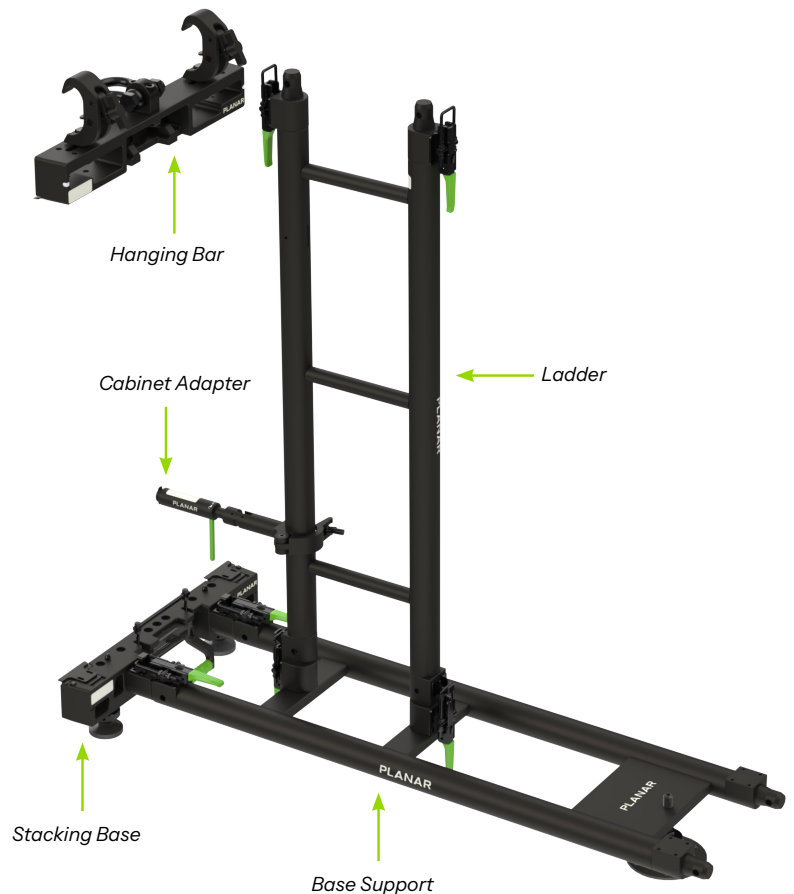

Ground Stack Frames

The Ground Stack Frame allows Mantis to be deployed as a stable free-standing video wall for applications where hanging installation is not preferred or practical. Built with the same focus on speed and simplicity as the Mantis platform, it supports quick assembly and disassembly to enable efficient deployment across a wide range of venues and event types.

Planar Mantis Series

	Model	Mantis 1.5 S	Mantis 1.9 S	Mantis 2.6 S	Mantis 2.6 L
Physical	Pixel Pitch	1.56mm	1.95mm	2.6mm	2.6mm
	Cabinet Dimensions	500 x 500 x 80mm	500 x 500 x 80mm	500 x 500 x 80mm	500 x 1000 x 80mm
	Cabinet Weight	6.8kg	6.8kg	6.8kg	11.0kg
	Cabinet Resolution (W x H)	320 x 320	256 x 256	192 x 192	192 x 384
	Module Configuration (W x H)	2 x 2	2 x 2	2 x 2	2 x 4
	Module Dimensions	250 x 250mm	250 x 250mm	250 x 250mm	250 x 250mm
	Module Resolution (W x H)	160 x 160	128 x 128	96 x 96	96 x 96
	Controller Compatibility	Brompton, Novastar	Brompton, Novastar	Brompton, Novastar	Brompton, Novastar
Visual	Brightness Max	1,500 nits	1,500 nits	1,500 nits	1,500 nits
	Contrast Ratio	4000:1	4000:1	4000:1	4000:1
	Color Temperature	3,000 - 10,000K	3,000 - 10,000K	3,000 - 10,000K	3,000 - 10,000K
	Viewing Angle, Horizontal	160°	160°	160°	160°
	Viewing Angle, Vertical	140°	140°	140°	140°
	Refresh Rate	7,680Hz	7,680Hz	7,680Hz	7,680Hz
	Scan Rate	1:10	1:8	1:12	1:12
	Max Frame Rate	120Hz	240Hz	240Hz	240Hz
Power	Power (V-AC)	100-240	100-240	100-240	100-240
	Power Supply	Single	Single	Single	Single
Miscellaneous	Operating Temperature	-20 to 40°C	-20 to 40°C	-20 to 40°C	-20 to 40°C
	Operating Humidity	10% to 80%	10% to 80%	10% to 80%	10% to 80%
	Storage Temperature	-30 to 60°C	-30 to 60°C	-30 to 60°C	-30 to 60°C
	Storage Humidity	10% to 85%	10% to 85%	10% to 85%	10% to 85%
	LED Lifetime	100,000Hrs	100,000Hrs	100,000Hrs	100,000Hrs
	Install Method	Free Standing, Hanging	Free Standing, Hanging	Free Standing, Hanging	Free Standing, Hanging
	Service Access	Rear	Rear	Rear	Rear
	Warranty	Planar Standard 3-Year Warranty	Planar Standard 3-Year Warranty	Planar Standard 3-Year Warranty	Planar Standard 3-Year Warranty
	Protection	IP40	IP40	IP40	IP40