

REVISION HISTORY					
ECO	ZONE	REV.	DESCRIPTION	DATE	APPR'D

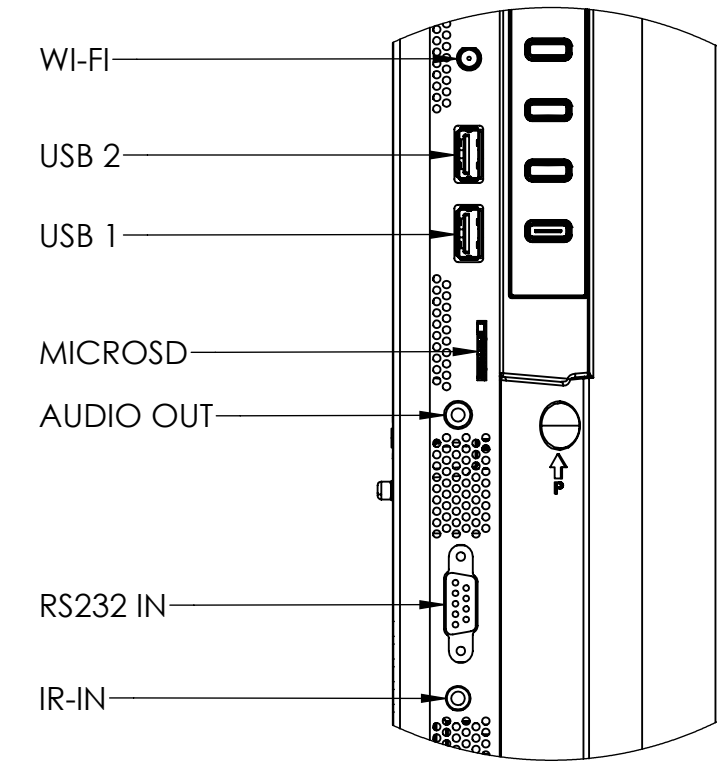

DETAIL A
SCALE 1 : 2

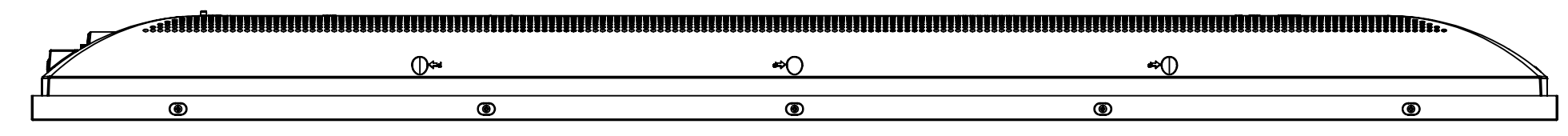
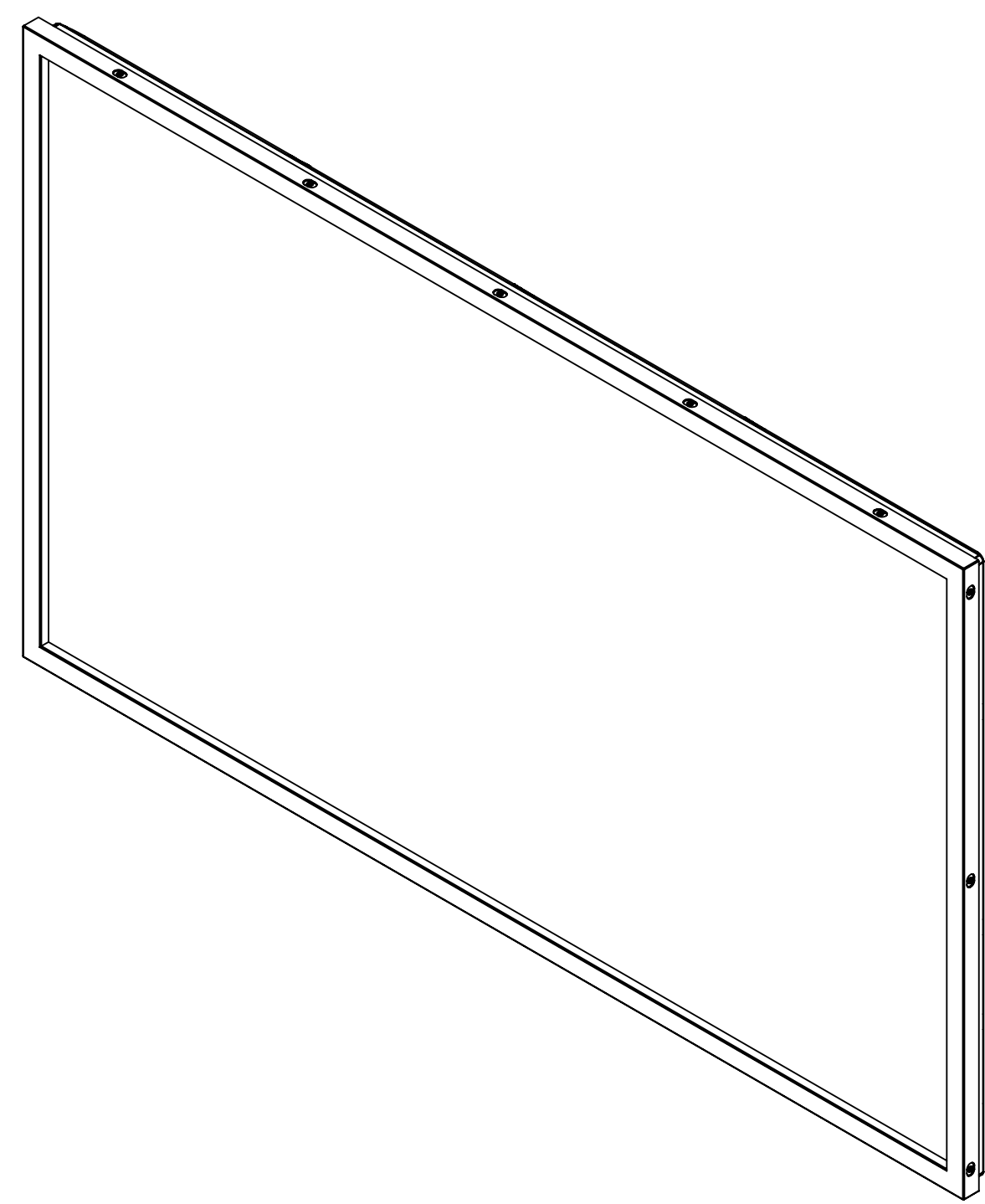

TOP VIEW

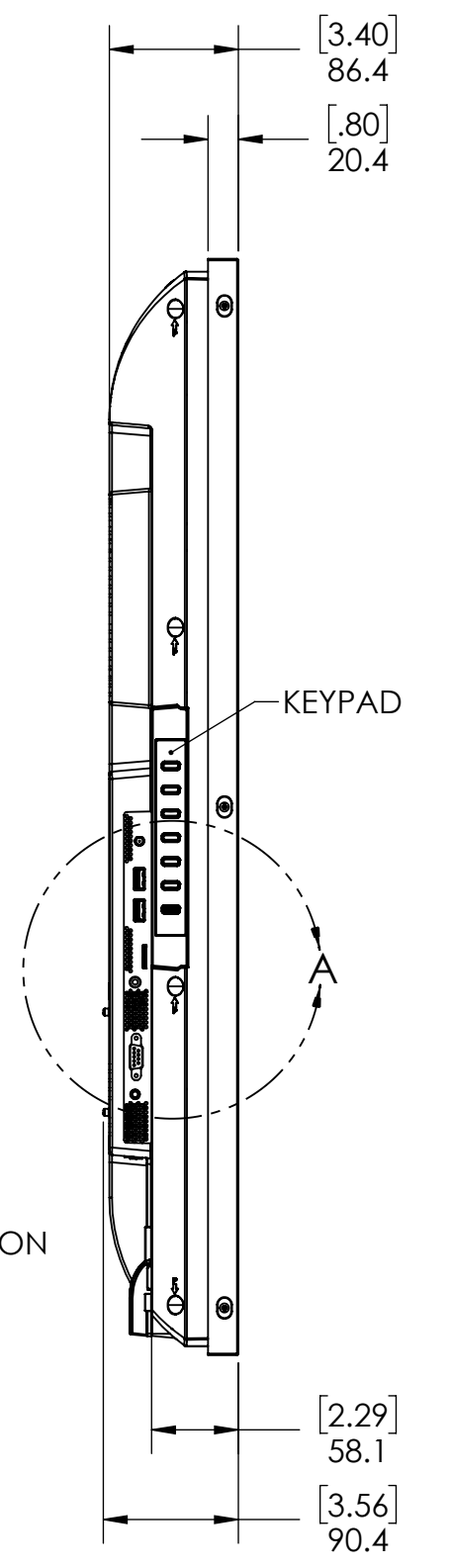
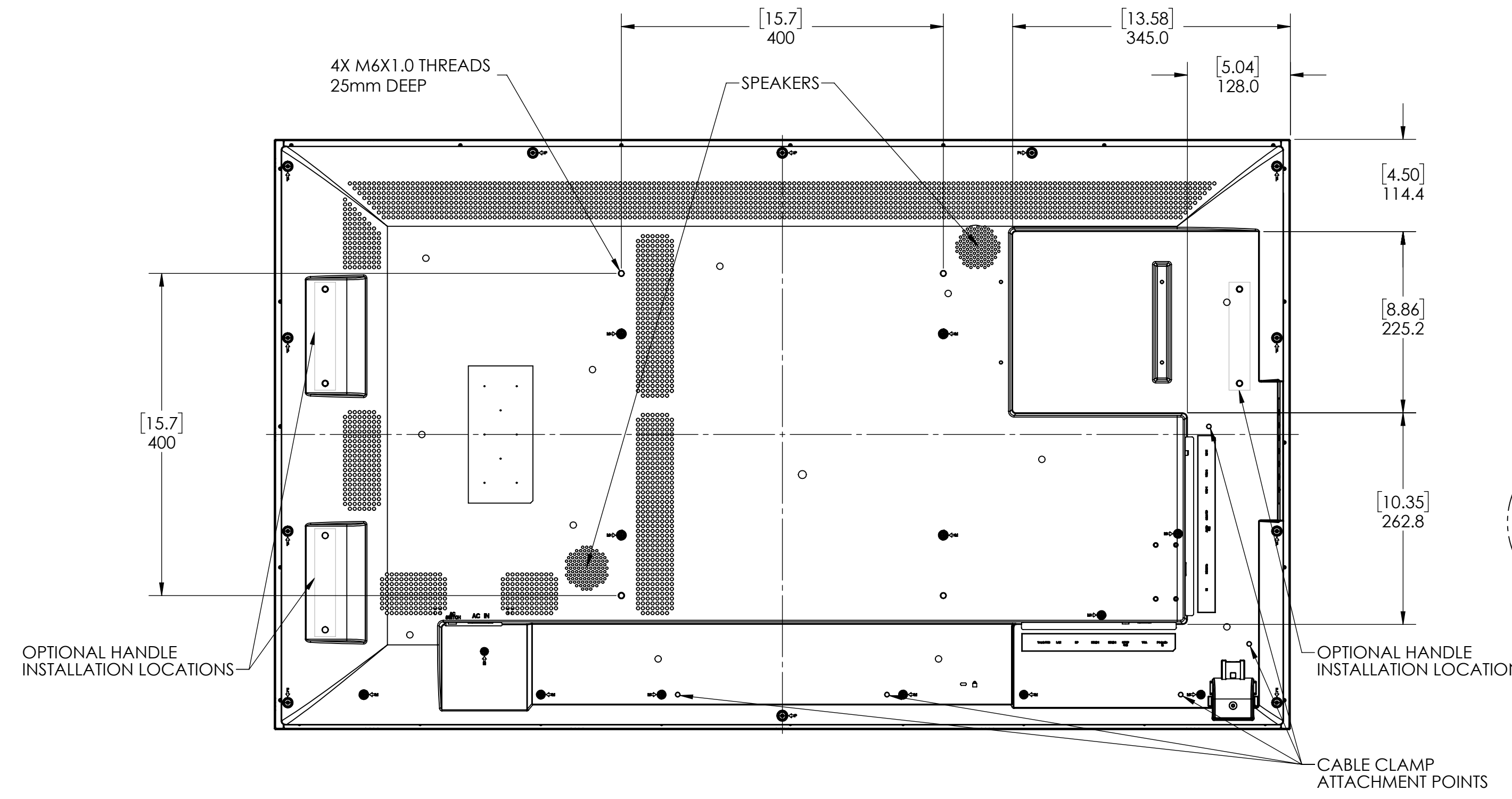
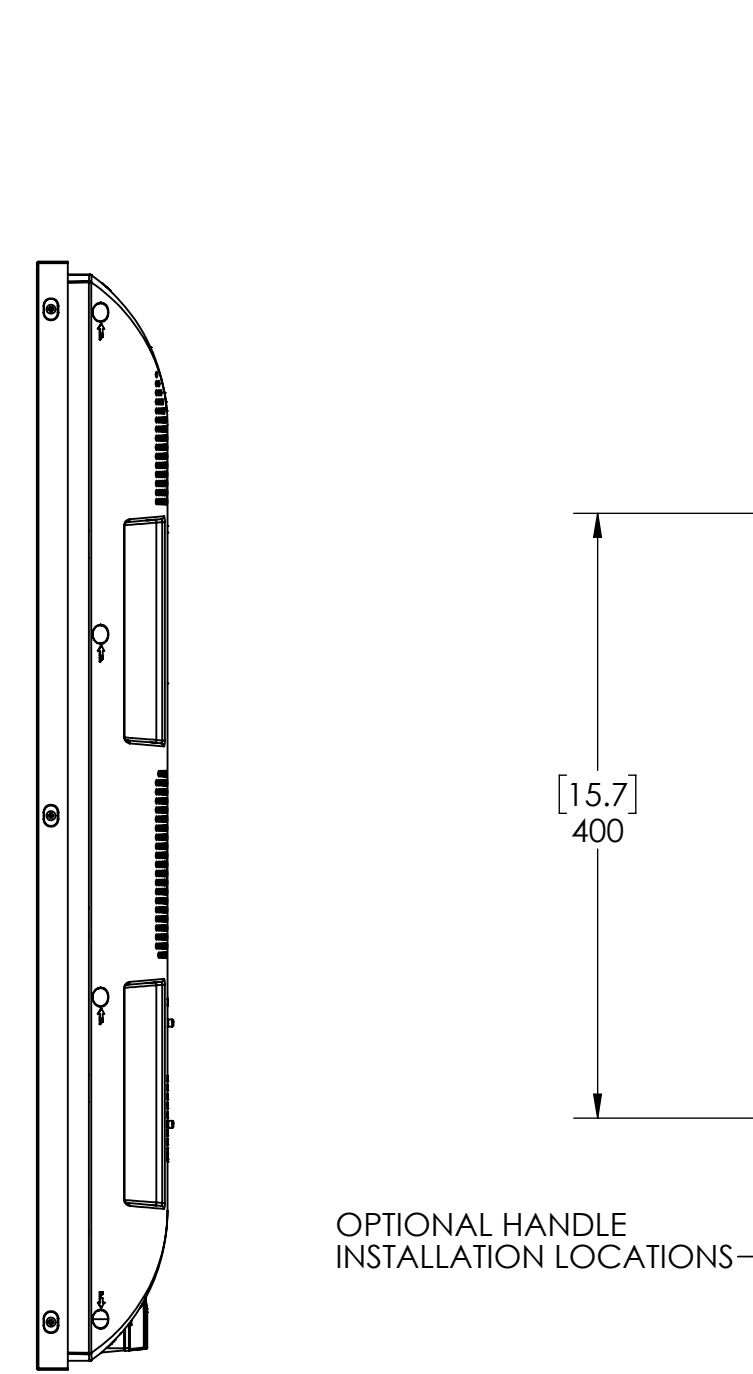

KEYPAD

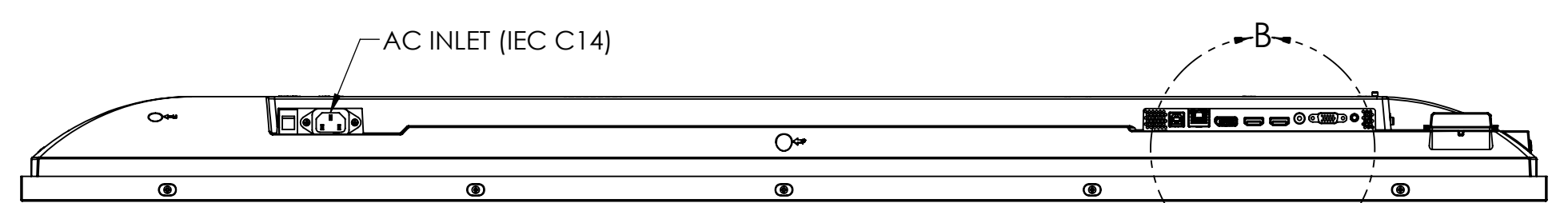
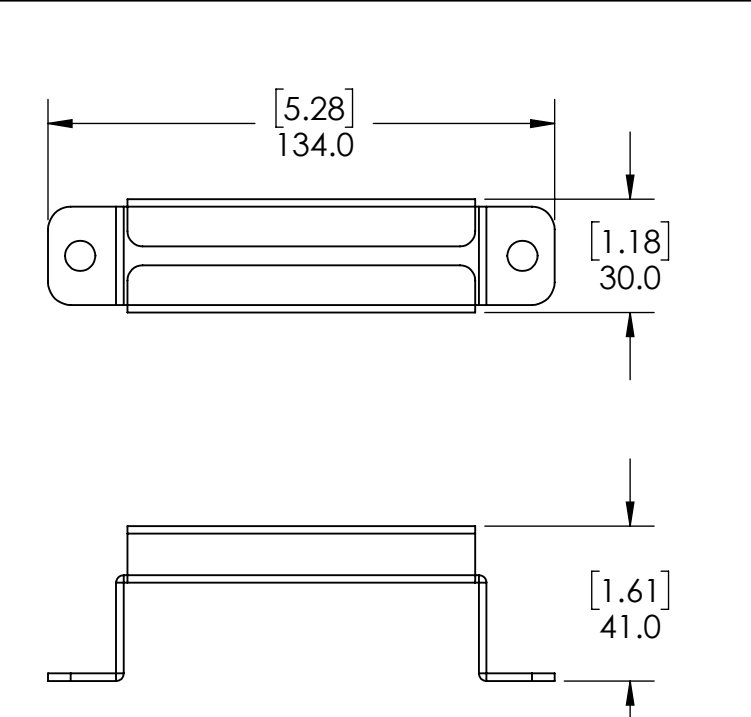
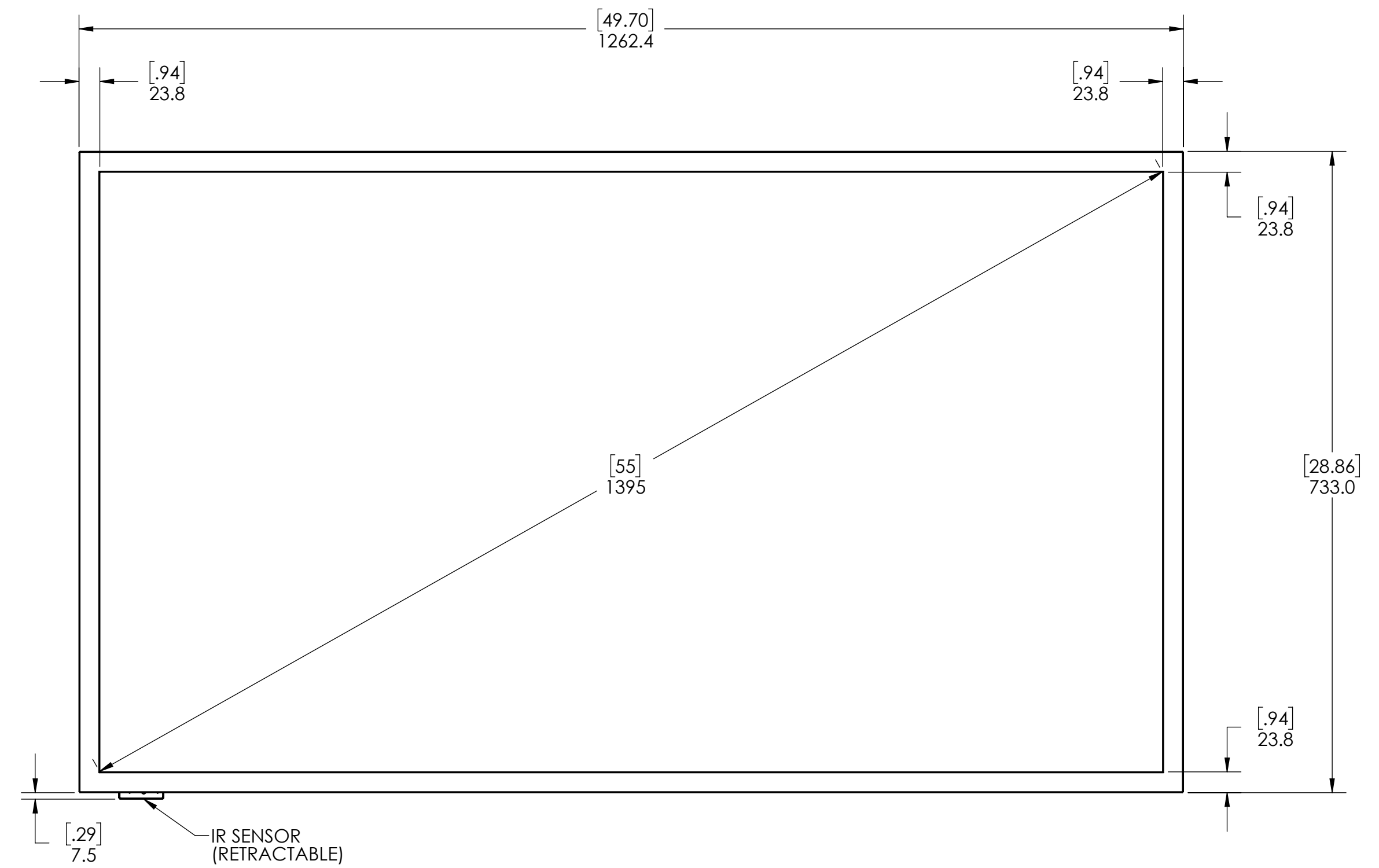

BOTTOM VIEW

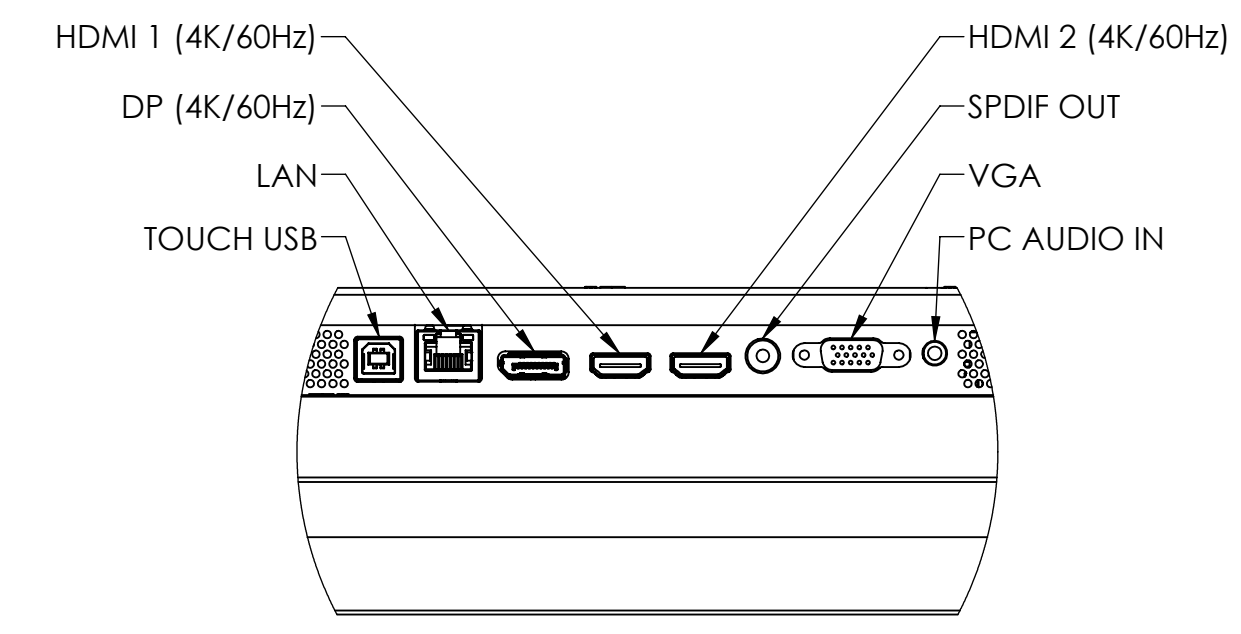

DETAIL B
SCALE 1 : 2

4. TOUCH GLASS RECESS FROM FRONT OF DISPLAY 11.2mm [.44in].
 3. PORTRAIT ORIENTATION IS ROTATED 90° COUNTERCLOCKWISE AS VIEWED FROM THE FRONT.
 2. KEEP PERFORATION AREAS CLEAR FOR VENTILATION.
 1. SPECIFICATIONS SUBJECT TO CHANGE WITHOUT NOTICE.
- NOTES: UNLESS OTHERWISE SPECIFIED.

UNLESS OTHERWISE SPECIFIED, DIMENSIONS ARE IN MILLIMETERS (INCHES)		ENGR BY			PLANAR SYSTEMS, INC. 1195 NE COMPTON DRIVE HILLSBORO, OR 97006 USA
TOLERANCES:		DRAWN BY	MRW		
X= ±1	XX= ±.25	CHECKED BY		TITLE	PS5574KT 998-1246-00
.X= ±.5	∠= ±1°	USED ON		SIZE	D
DIMENSIONING AND TOLERANCING PER ASME Y14.5M-1994		MATERIAL		PART NO	-
THIRD ANGLE PROJECTION		FINISH		DRAWING NO	PS5574KT OUTLINE
				REV	A
SCALE	1:5	DO NOT SCALE	SHEET	1 OF 1	

THIS DRAWING CONTAINS INFORMATION PROPRIETARY TO PLANAR SYSTEMS, INC. ANY REPRODUCTION IN PART OR WHOLE WITHOUT THE WRITTEN PERMISSION OF PLANAR SYSTEMS IS PROHIBITED. THIS DRAWING IS SUPPLIED FOR INFORMATION, IDENTIFICATION, ENGINEERING, EVALUATION, AND/OR INSPECTION PURPOSES ONLY AND MAY NOT BE USED AS BASIS FOR THE MANUFACTURING OF PRODUCTS OR THE FURNISHING OF SERVICES TO PLANAR SYSTEMS OR TO ANY THIRD PARTY UNLESS AUTHORIZED IN WRITING BY PLANAR SYSTEMS.