

| REVISION HISTORY |      |      |             |      |        |
|------------------|------|------|-------------|------|--------|
| ECO              | ZONE | REV. | DESCRIPTION | DATE | APPR'D |
|                  |      |      |             |      |        |

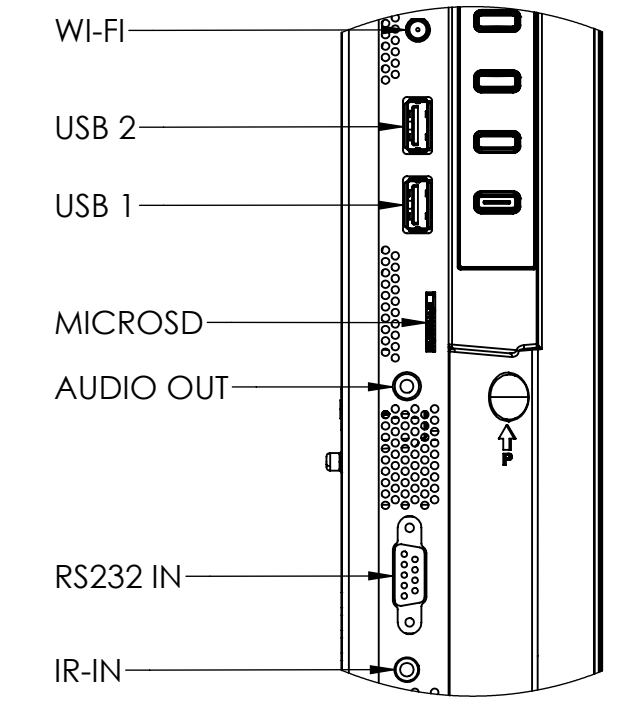

DETAIL A  
SCALE 1 : 2

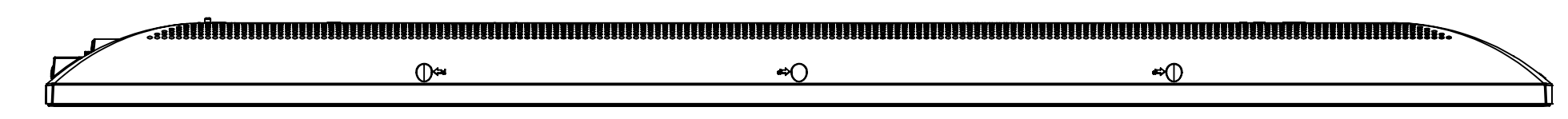
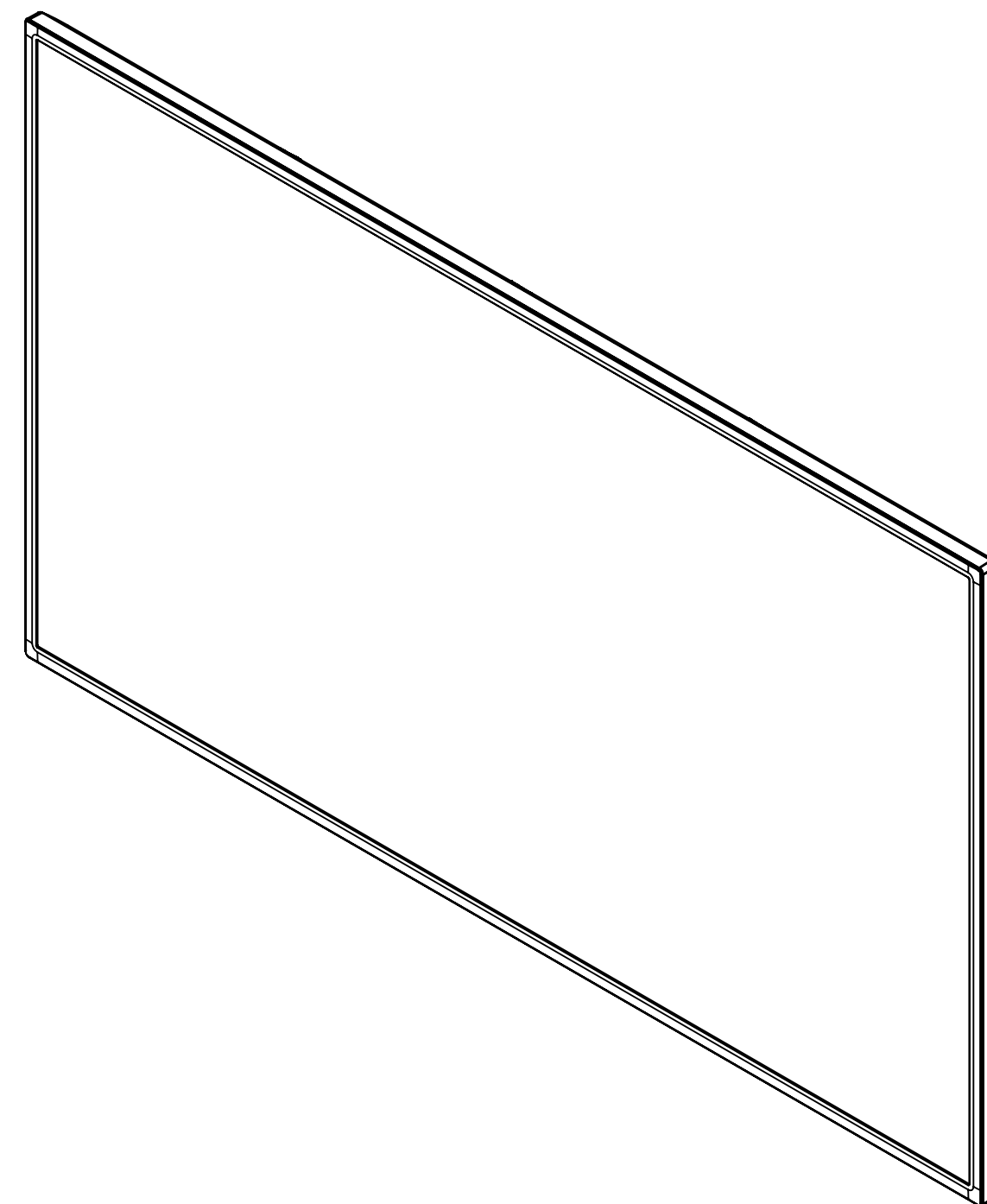

TOP VIEW

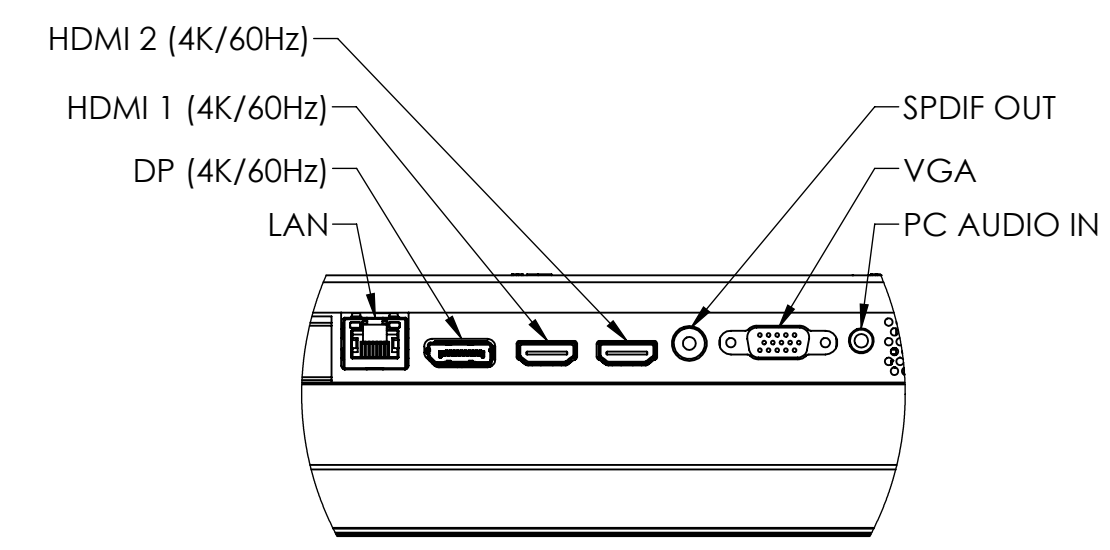
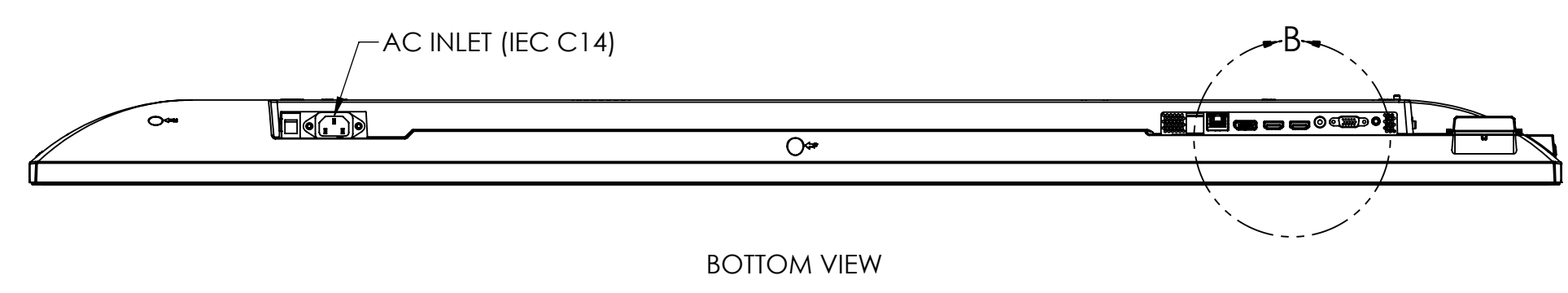
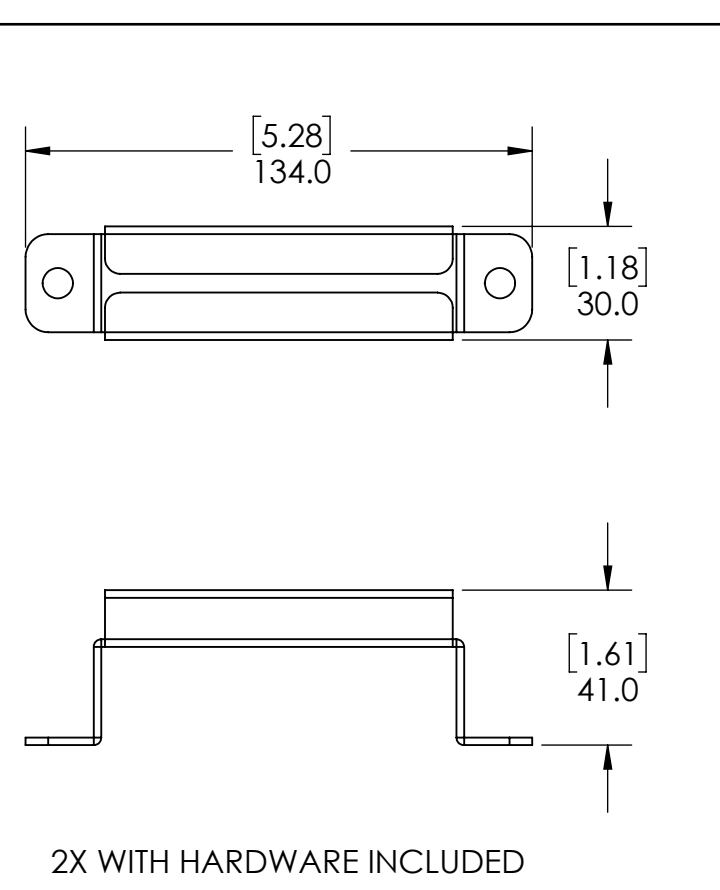
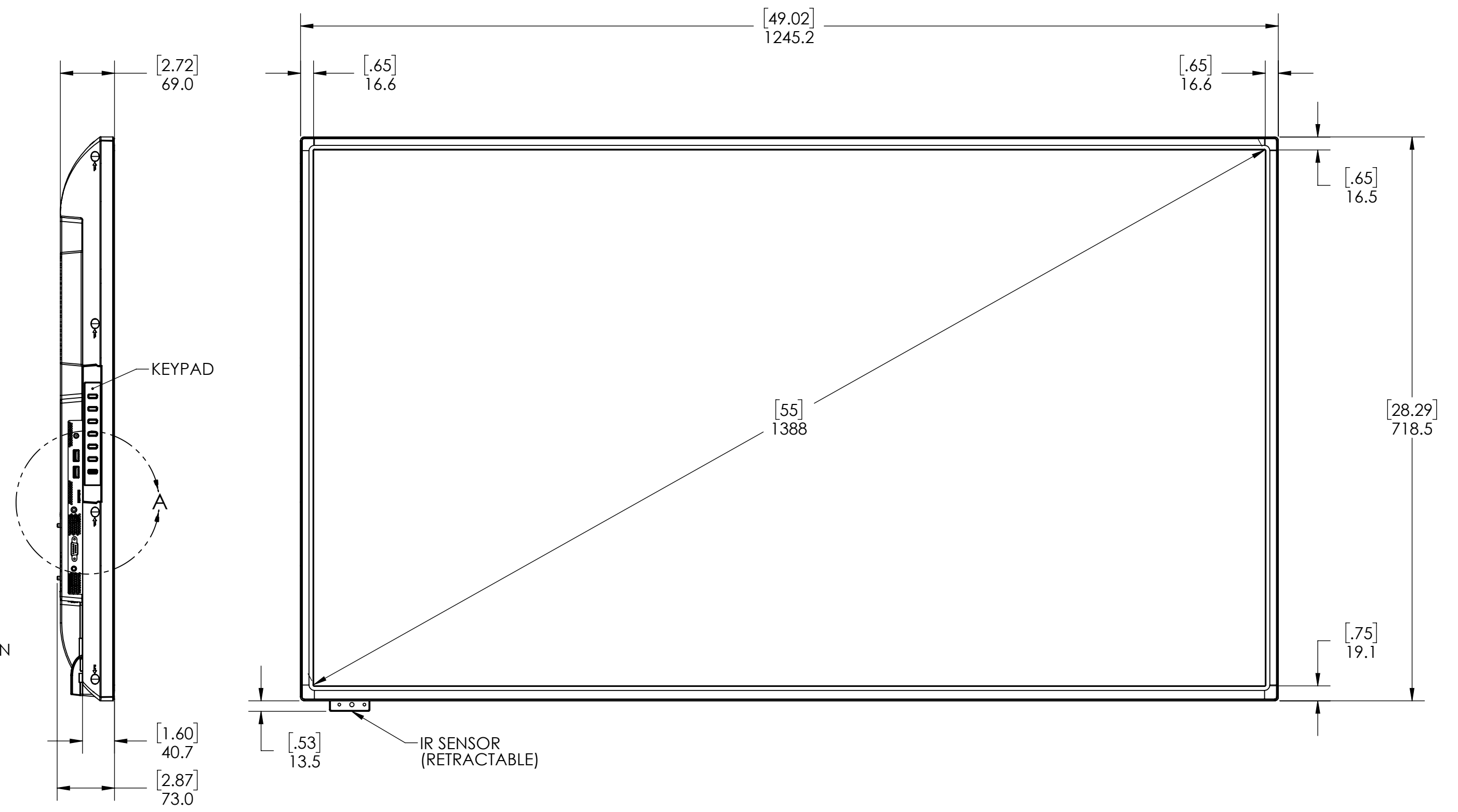
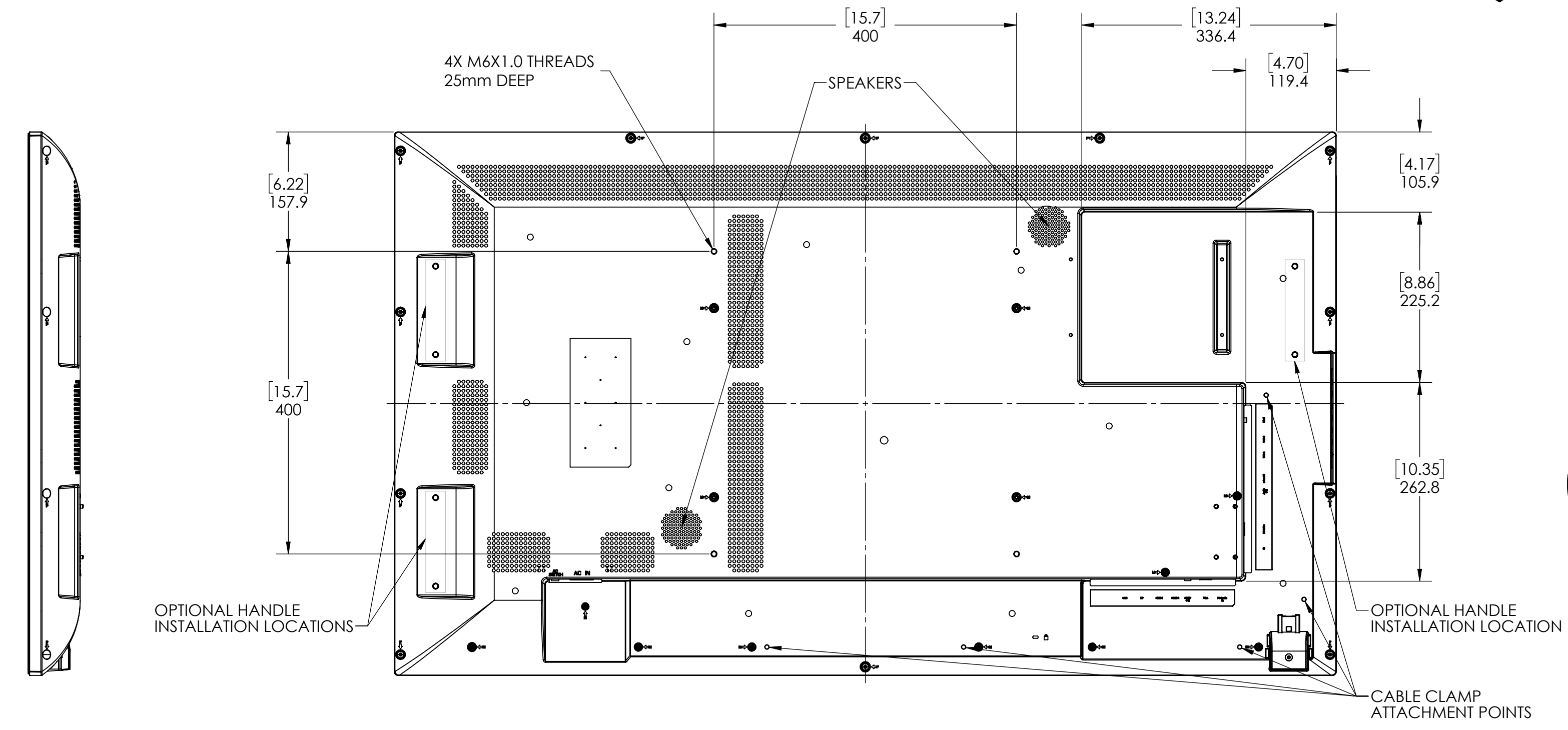

DETAIL B  
SCALE 1 : 2

3. PORTRAIT ORIENTATION IS ROTATED 90° COUNTERCLOCKWISE AS VIEWED FROM THE FRONT.
  2. KEEP PERFORATION AREAS CLEAR FOR VENTILATION.
  1. SPECIFICATIONS SUBJECT TO CHANGE WITHOUT NOTICE.
- NOTES: UNLESS OTHERWISE SPECIFIED.

|   |          |            |         |                     |  |
|---|----------|------------|---------|---------------------|--|
| UNLESS OTHERWISE SPECIFIED DIMENSIONS ARE IN MILLIMETERS (INCHES) |          | ENGR BY    |         |                     | PLANAR SYSTEMS, INC.<br>1195 NE COMPTON DRIVE<br>HILLSBORO, OR 97006 USA |
| TOLERANCES:   |          | DRAWN BY   | 21OCT19 |                     |  |
| X= ±1   | XX= ±.25 | CHECKED BY | MRW     | TITLE               |  |
| .X= ±.5   | ∠= ±1°   | USED ON    |         | PS5574K 998-1245-00 |  |
| DIMENSIONING AND TOLERANCING PER ASME Y14.5M-1994                 |          | MATERIAL   |         | SIZE                | PART NO.   |
| THIRD ANGLE PROJECTION  |          | FINISH     |         | D                   | -  |
|   |          |            |         | SCALE               | DRAWING NO.  |
|   |          |            |         | 1:5                 | PS5574K OUTLINE  |
|   |          |            |         | DO NOT SCALE        | REV  |
|   |          |            |         | SHEET               | A  |
|   |          |            |         | 1 OF 1              |  |

THIS DRAWING CONTAINS INFORMATION PROPRIETARY TO PLANAR SYSTEMS, INC. ANY REPRODUCTION IN PART OR WHOLE WITHOUT THE WRITTEN PERMISSION OF PLANAR SYSTEMS IS PROHIBITED. THIS DRAWING IS SUPPLIED FOR INFORMATION, IDENTIFICATION, ENGINEERING, EVALUATION, AND/OR INSPECTION PURPOSES ONLY AND MAY NOT BE USED AS BASIS FOR THE MANUFACTURING OF PRODUCTS OR THE FURNISHING OF SERVICES TO PLANAR SYSTEMS OR TO ANY THIRD PARTY UNLESS AUTHORIZED IN WRITING BY PLANAR SYSTEMS.