

ELECTROLUMINESCENT DISPLAYS

CHRISTOPHER N. KING

Executive Vice President / Chief Technical Officer

Planar Systems, Inc., 1195 NW Compton Drive, Beaverton, OR 97006, chris_king@planar.com

ABSTRACT

This paper will review the electrical and optical properties of both monochrome and color electroluminescent (EL) displays. A simple electrical model for thin film electroluminescent (TFEL) device operation will be presented and used to describe the luminance and power consumption of TFEL devices. The basic material characteristics desirable for EL phosphors will be described. Progress in the development of monochrome and color EL displays will be presented including TFEL and Active Matrix EL devices and phosphors.

INTRODUCTION

The phenomenon of electroluminescence (EL) is the non-thermal conversion of electrical energy into luminous energy. There are two classes of EL devices. In the familiar light emitting diode (LED) devices, light is generated by electron-hole pair recombination near a pn junction. Commercial LEDs have been fabricated from inorganic materials like GaAs, but recently there has been significant progress with the development of organic LED devices (OLEDs). This paper, however, will focus on the other class of EL devices in which the light is generated by impact excitation of a light emitting center (called the activator) by high energy electrons in materials like ZnS:Mn. The electrons gain their high energy from an electric field, and thus, this type of EL is often called **high field electroluminescence**. This review will focus on high field thin film electroluminescent (TFEL) devices. In these devices it is the behavior of the majority carriers (the electrons) that predominately determine the device physics.

THIN FILM EL (TFEL) DISPLAYS

TFEL Device Structure

Figure 1 shows the device structure for a thin film EL (TFEL) device [1]. First, let us discuss the function of the individual layers of the TFEL device. The central layer is the thin film phosphor which emits light when a large enough electric field is applied across it. The required field level is on the order of 1.5 MV/cm. Because of this high field level, any imperfection in the thin film stack which produces a short circuit would cause a destructive amount of energy to be dissipated if the phosphor were directly connected to the electrodes. Therefore, current limiting layers (the insulators) are needed on either side of the phosphor layer to form a reliable device structure. The insulators limit the maximum current to the capacitive charging and discharging displacement current level. Finally, electrodes on the top and bottom of the device complete a basic capacitive structure. At least one set of these electrodes should be transparent to permit viewing of the emitted light.

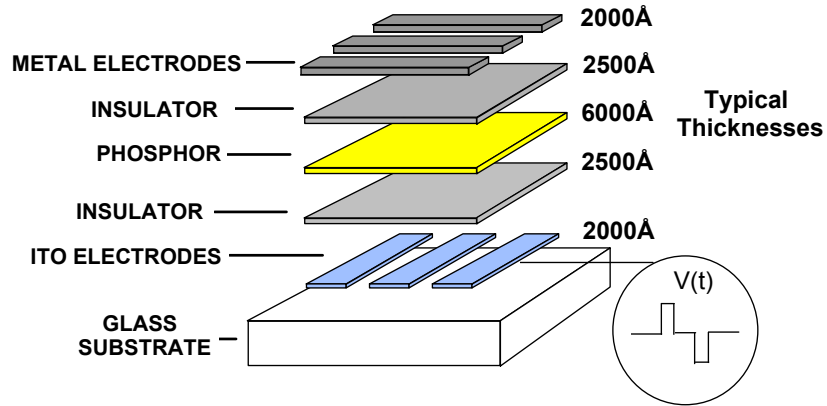

Figure 1: Schematic Diagram of Conventional TFEL Structure

TFEL Operating Characteristics

The luminance-voltage (L-V) and efficiency-voltage (η -V) characteristics of a typical ZnS:Mn TFEL device are shown in Figure 2. This curve features a threshold voltage below which little light is emitted, a steeply rising characteristic above threshold, and finally a saturation region. This highly non-linear characteristic provides the device with the capability to be electrically addressed at a very high multiplexing ratio while maintaining excellent contrast. The luminous efficiency curve shows a steep rise at threshold reaching a maximum at a voltage corresponding to the steepest slope of the L-V curve. The efficiency then gradually decreases with increasing voltage as a result of saturation in the emission from the excited Mn centers. A typical ZnS:Mn TFEL device has a peak efficiency of 6 lumens per Watt (lm/W). At the normal display operating conditions of 40 volts above threshold the efficiency is 3 lm/W. The performance level of a commercial state-of-the-art TFEL 320x240 (QVGA) display with high contrast electrodes is now an areal **luminance of 150 nits** and **contrast ratio of 150:1 in a 500 lux ambient**. Because these displays have wide viewing angles (> 160 degrees) and operate at video rates, TFEL technology has all the characteristics required to produce high information content flat panel displays with the image quality of the CRT. The solid state nature of EL displays makes them extremely rugged which is often a desirable characteristic for a flat panel display when used in portable applications.

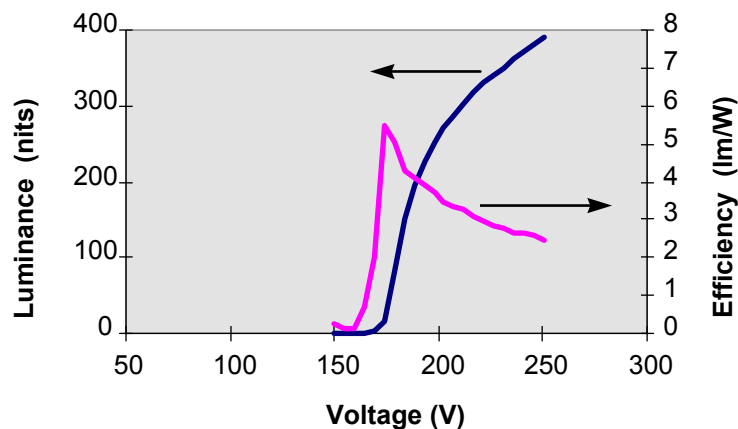

Figure 2: Luminance - Voltage and Efficiency - Voltage Characteristics of a ZnS:Mn TFEL Device

Model for a TFEL Device

Alt [2] has proposed the simple model shown in Figure 3 which contains the essential device physics of a TFEL device and in practice this model has been found to accurately represent the most significant characteristics of a TFEL device. This model treats the insulator layers of the device as perfect capacitors. The thin film phosphor layer also behaves as a capacitor below a threshold voltage as represented by the Zener breakdown voltage of the back to back diodes. When the internal phosphor voltage is above threshold, real current flows in the phosphor layer and excites the light emission center. The luminance of the device is proportional to power consumed in the real current branch of the circuit with the proportionality constant being the experimentally determined efficiency, η , which has units of lumens per watt.

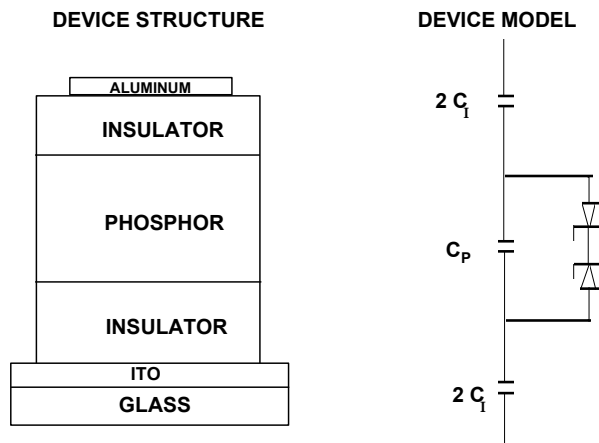

Figure 3: TFEL Device Structure and Circuit Model

Figure 4 shows a charge-voltage (Q-V) diagram for the device model of Figure 3. For voltages below the threshold voltage, the Q-V diagram is a straight line, and the slope of the straight line is the capacitance of the series combination of the insulator and phosphor layers. Above threshold, the diodes begin to conduct and the slope of the Q-V diagram now increases to the capacitance of the insulator layers alone, since the capacitance of the phosphor layer is now shorted out. The charge transported across the phosphor layer is stored at the phosphor/insulator interface and creates an internal polarization field that opposes the field generated by the externally applied voltage. The charge at the interface continues to build up until the voltage across the diode drops below threshold at which time the charge transport is terminated. When the external voltage is reduced, the voltage across the diodes remains below threshold, and thus the charge transported remains at the interface, and the magnitude of this charge is represented by value of Q for $V = 0$. This non zero value of Q for $V = 0$ leads to a Q-V curve that "opens up" into a parallelogram for voltages above threshold. The area inside this parallelogram represents the energy dissipated in generating the light from the EL device. The power consumption of a typical TFEL display that is driven at 60 light pulses per second is **8 milliwatts per square centimeter**.

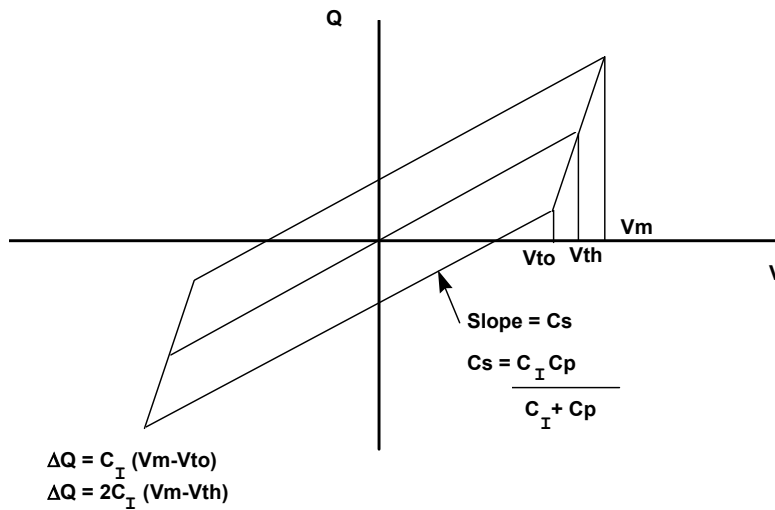

Figure 4: Q-V Characteristic of an EL Device

The performance of a TFEL device is a function of both the efficiency of the phosphor layer and the quantity of charge transferred across the phosphor layer which is controlled by the capacitance of the insulator layers. The figure of merit of the insulator layers, which is defined as the product of the dielectric constant and the electrical breakdown strength, plays a key part in the performance of the TFEL device because the larger the capacitance of the insulators (i.e. the thinner the thickness of the insulators and the larger their dielectric constant) the more charge that is transferred through the phosphor and the higher the luminance for a given modulation voltage. The table below illustrates how the low power performance of TFEL displays has been improved over that of the first generation of commercial monochrome TFEL devices by optimizing the materials and device structure.

Table I: Improvement in TFEL Performance

QVGA 5inch Diagonal	First Generation	Today's TFEL Capability
Luminance (Areal)	60 nits	60 nits
20% Pixel On	2.4 W	1.1 W
100% Pixels On	3.1 W	2.2 W

EL PHOSPHOR MATERIALS

In general, phosphors, whether used for TFEL or CRT devices, consist of a host material doped with an activator which is the light emission center. The classical yellow EL phosphor consists of a ZnS host lattice doped with Mn atom light emission centers. To be a phosphor host lattice, a material must satisfy the basic requirement of having a band gap large enough to emit visible light without absorption. This limits the class of possible materials to large band gap semiconductors ($E_g > 3.0$ eV) and insulators. The classical CRT phosphor host materials are the II-VI compounds and the rare earth oxides and oxysulfides.

A priori, these same materials could be good hosts for EL devices. However, EL host materials have the additional requirement of providing a medium for the efficient transport of high energy (> 2 eV) electrons. To date, only the II-VI materials (for example ZnS and SrS) have been used in commercial devices. However there has been recent research activity on the use of oxide phosphors such as $ZnGa_2O_4$ and $ZnSiO_4$ [3,4], but so far these materials seem to

require very high processing temperatures, and also the efficient transport of hot electrons remains an issue.

Color EL Phosphors

The development of efficient EL phosphor materials for the primary red, green and blue colors has been the basic materials challenge for the realization of a practical full color TFEL display technology. There have been two parallel avenues explored for color EL: 1) the development of an efficient white (or broad band) phosphor that can be filtered to produce an RGB display or 2) the development of efficient red, green, blue primary color EL phosphors for the spatially patterned phosphor structure.

The most efficient red EL emission has been achieved using the ZnS:Mn phosphor layer and an inorganic thin film filter. An efficiency of 0.8 lumens per watt has been reported for this red emitting multilayer structure [5]. Other phosphors that have been investigated for red EL include CaS:Eu and ZnS:Sm which show good red chromaticity without filtering but they have not achieved the luminance level required for a practical color TFEL display. An efficiency of 0.2 lm/W has been reported for a CaSSe:Eu film [6], but this is still a factor of four less than the efficiency of the red filtered ZnS:Mn.

The most efficient green EL phosphor is terbium activated ZnS. A luminous efficiency of over 1 lm/W and an EL luminance of 100 nits has been achieved at a 60 Hz drive frequency for sputtered ZnS:TbOF [7]. The emission spectrum of ZnS:Tb has a sharp peak at 545 nm and CIE coordinates of $x = 0.31$, $y = 0.60$ which are close to the green coordinates for color CRTs. Efficient green EL can also be produced by filtering the emission of ZnS:Mn. However, the chromaticity of the green filtered emission from ZnS:Mn has CIE coordinates of $x = 0.47$, $y = 0.53$, and is thus a yellow-green color. SrS:Ce [8] is an efficient blue-green phosphor whose CIE coordinates can be manipulated by varying the Ce concentration, the codopants and the processing conditions. The ALD process can produce a SrS:Ce phosphor with CIE coordinate of $x = 0.28$ and $y = 0.53$ which is a better green chromaticity than that of filtered ZnS:Mn.

Blue Phosphors

The first material to show promise for the blue EL phosphor was SrS:Ce [8]. The brightness, efficiency and chromaticity of this phosphor has been improved over the years by modifying the process and dopant concentrations. The group at the Heinrich Hertz Institute has achieved the best efficiency of over 1 lm/W with an evaporation process and codoping with Ag (SrS:Ce,Ag) [9]. However, this phosphor still needs to be filtered to produce a good blue and the filtered efficiency is less than 0.1 lm/W. The group at Westaim Corporation has achieved the best blue chromaticity in SrS:Ce with CIE coordinates of $x = 0.19$, $y = 0.36$ with a high purity evaporation process [10].

To improve the blue TFEL chromaticity the group at Planar Systems investigated the SrGa₂S₄:Ce and Ca₂Ga₄S₄:Ce blue phosphors [11]. These phosphors have an excellent blue chromaticity ($x = 0.15$, $y = 0.10$) but to date these thiogallate materials have only exhibited a rather low efficiency (0.02 - 0.03 lm/W). This low efficiency is thought to be the result of inefficient hot electron transport in these materials.

In 1997, Planar discovered that SrS:Cu is a reasonably efficient (0.2 lumens per watt) blue phosphor with a good blue chromaticity ($x = 0.15$, $y = 0.23$) [12]. This was a very surprising discovery to many people, because the traditional CRT phosphor, copper doped ZnS, is not an efficient EL phosphor. Subsequent studies of copper doped SrS indicate that the copper

+1 ion forms a local center in SrS rather than a donor acceptor pair center as it does in ZnS. The different character of the copper dopant center in SrS:Cu enables this material to be an efficient EL phosphor. Codoping SrS:Cu with Ag further improves the blue chromaticity to $x = 0.17$, $y = 0.16$ while maintaining the same brightness and luminous efficiency of this phosphor [13]. The emission spectra for SrS:Cu, SrS:Cu,Ag and SrS:Ce phosphors are shown in Figure 5. The SrS:Cu,Ag phosphor has a higher normalized luminous efficiency (See figure 6).

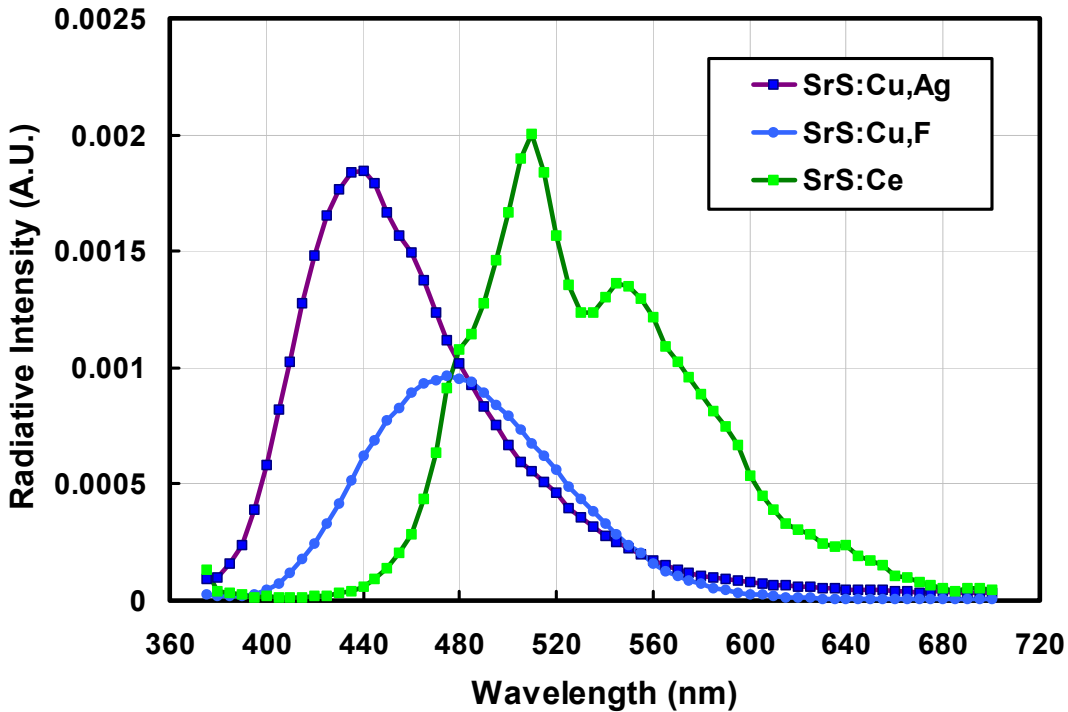

Figure 5: EL Emission Spectra of SrS:Cu, and SrS:Ce

Recently, another TFEL blue phosphor, $\text{BaAl}_2\text{S}_4:\text{Eu}$, with deep blue chromaticity ($x = 0.10$, $y = 0.11$) was discovered by the group at Meiji University [14]. They achieved an efficiency of 0.15 lumens per watt for this blue chromaticity using conventional TFEL insulators. More recently, iFire and TDK have optimized the $\text{BaAl}_2\text{S}_4:\text{Eu}$ blue phosphor composition and applied it to the thick dielectric electroluminescent (TDEL) structure [15,16]. Using this EL structure they achieved a higher blue efficiency (0.45 lumens per watt) with color coordinates $x = 0.12$, $y = 0.11$. The progress in blue TFEL phosphor efficiency is shown in Figure 6. There are now two blue EL phosphors that have the capability of producing a color EL display with good blue chromaticity.

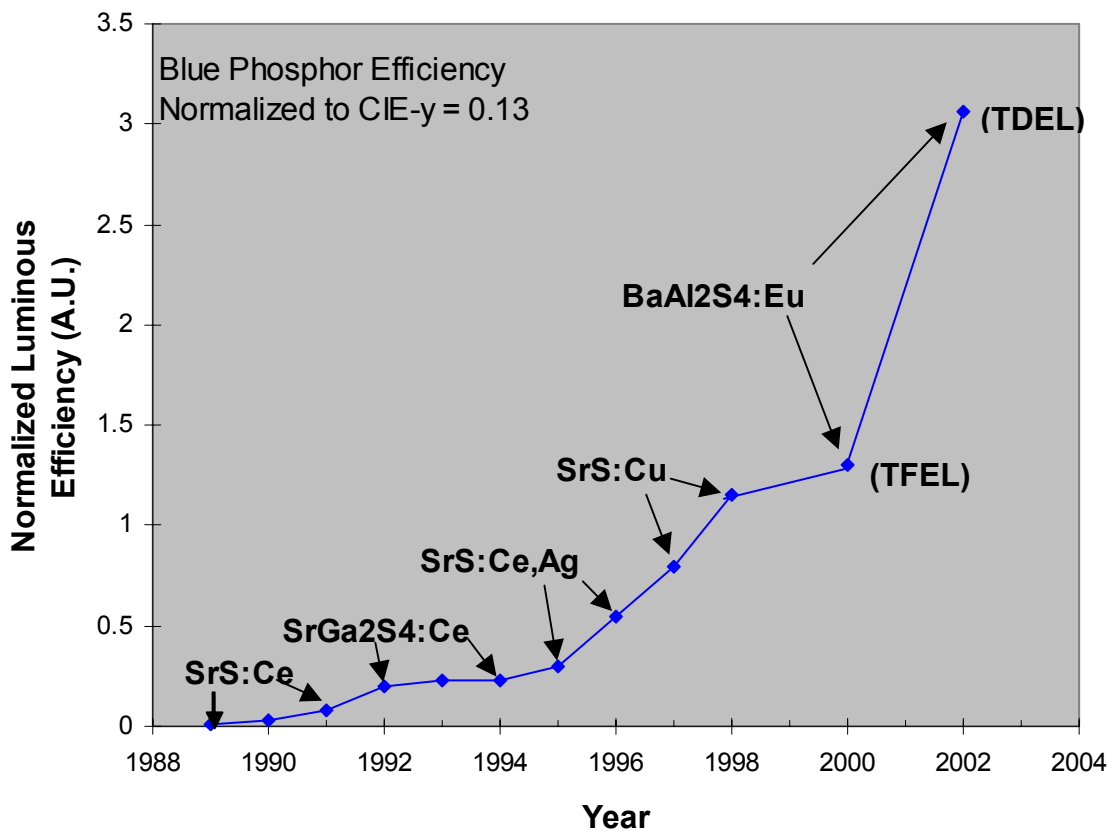

Figure 6: Progress in EL Blue Phosphor Efficiency

White Phosphors

White EL phosphors based on rare earth doped alkaline earth sulfides for filtered color TFEL devices were first reported by the group at Totterri University in 1987 [17]. In recent years broad band "white" emission from stacked layers of SrS:Ce and ZnS:Mn has achieved a luminance level required for filtered color TFEL displays. This multilayer "white" phosphor has been developed by several groups using different deposition techniques including multisource deposition, reactive evaporation, and ALD [18,19,20]. The highest white luminance at 60 Hz of 470 nits has been reported by Planar using atomic layer deposition to deposit the dual layer of SrS:Ce/ZnS:Mn phosphor [21]. However, the emission of the SrS:Ce/ZnS:Mn phosphor is not a true white color. A true white EL emission has been obtained using the SrS:Cu/ZnS:Mn phosphor [22]. A 192 x 192 (3ATI) monochrome white EL display operating at 460 Hz has achieved a luminance of 198 cd/m² with CIE coordinates of x = 0.40, y = 0.38.

Table II: TFEL Phosphor Performance Summary

Emission Color	Phosphor Material	CIE X	CIE Y	Luminance (nits @ 60Hz)
Yellow	ZnS:Mn	0.50	0.50	400
Red	ZnS:Mn/Filtered	0.65	0.35	70
	CaSSe:Eu	0.66	0.33	25
Green	ZnS:TbOF	0.30	0.60	100
	ZnS:Mn/Filtered	0.47	0.53	160
	SrS:Ce	0.28	0.53	110
Blue	SrS:Ce	0.19	0.36	100
	SrGa ₂ S ₄ :Ce	0.15	0.10	5
	CaGa ₂ S ₄ :Ce	0.15	0.19	10
	SrS:Cu	0.17	0.16	28
	BaAl ₂ S ₄ :Eu	0.12	0.11	113*
White	SrS:Ce/ZnS:Mn	0.46	0.50	470
	SrS:Cu/ZnS:Mn	0.45	0.43	240

* TDEL Device Structure

COLOR TFEL DISPLAYS

In earlier work both the patterned red, green, blue phosphor and the patterned filter "color by white" approach were investigated for color TFEL displays. But the more recent work has focused on the "color by white" structure shown in Figure 7. In this device structure a broad band "white" phosphor is used in combination with a patterned color filter. This structure has the advantage of maintaining the simple device fabrication sequence of a monochrome TFEL display (i.e., no patterning of the thin film phosphor or insulator layers) and achieves color by laminating a patterned color filter to the EL device at the end of the process.

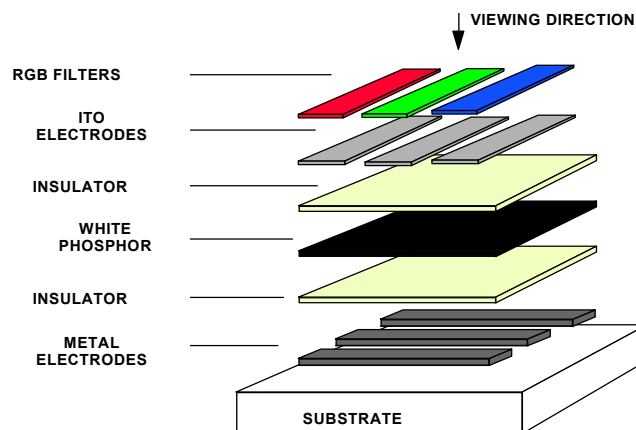

Figure 7: Diagram of Color by White Structure

Using this approach, the group at Planar International has demonstrated a 5" diagonal 340(x3)x240 QVGA color TFEL display with the SrS:Ce/ZnS:Mn phosphor and has achieved a

brightness of 70 nits using a frame frequency of 350 Hz [23]. Table III lists the areal luminance and CIE coordinates for the primary display colors. Further improvement in the color gamut of this display is expected by replacing the SrS:Ce layer with the new SrS:Cu blue phosphor.

Table III: Performance of Color by White QVGA TFEL Display

Color	Luminance (nits)	CIE (x,y)
Red	21	0.61,0.38
Green	44	0.46,0.51
Blue	7	0.28,0.41
White	70	0.36,0.43

COLOR TDEL DISPLAYS

Recently, color thick film dielectric (TDEL) electroluminescent displays have been developed by iFire Technology and TDK Corporation (15,16). Figure 8 shows a cross-section diagram of a 2-phosphor color TDEL display. This display is fabricated on an opaque alumina substrate. The bottom dielectric layer is a high-K thick film dielectric material which is resistive to dielectric breakdown. The high-K dielectric structure also enhances the EL luminance because it produces higher transported current in the phosphor layers. The 2-phosphor structure uses ZnMgS:Mn for red and green emission and BaAl₂S₄:Eu for blue. A color filter plate is used to separate the red and green colors, and improve the contrast ratio as well as the color purity. TDK has achieved a white luminance of 150 cd/m² for a 4.25" diagonal TDEL panel using this structure. The panel has good RGB color coordinates and high contrast ratio under indoor ambient lighting conditions.

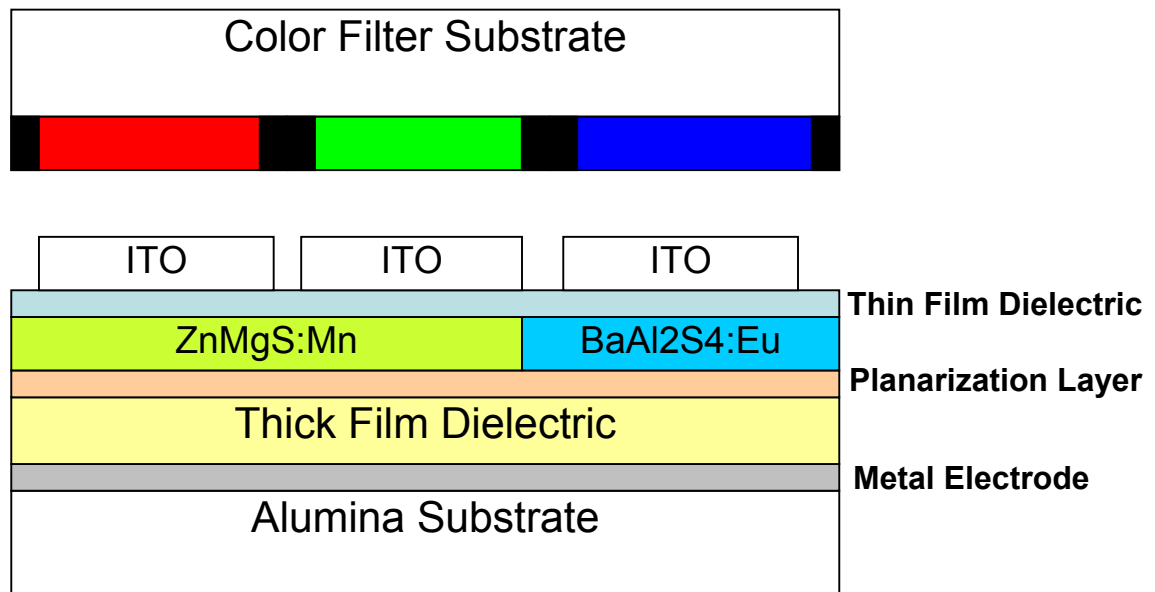

Figure 8: Diagram of 2-Phosphor Color TDEL Structure

ACTIVE-MATRIX EL (AMEL) DISPLAYS

Introduction

There is a growing interest in miniature high resolution displays for head mounted and personal viewer applications. For these applications the display diagonal should be in the size range of 0.3 inch to 1.0 inch. Compact optics are used with these displays to project the image of the display to an effective screen size ranging from a desk top monitor to the full immersion field of view of virtual reality.

AMEL is a candidate display technology for miniature displays because of the high luminance, low weight, compact size, and ruggedness. AMEL devices have been demonstrated with resolutions up to 2000 lines per inch, high contrast, fast response, and a wide operational temperature range. Compared with passive matrix addressing, the active-matrix addressing of EL displays provides reduced power consumption, higher brightness, and expanded gray scale capability.

AMEL Device Structure

The AMEL device is processed on a silicon wafer substrate using the inverted EL structure with a transparent ITO top electrode. The lower EL electrode is the top metallization layer of the silicon IC. The atomic layer deposition (ALD) process has been exclusively employed for AMEL film deposition because of the excellent conformal coating characteristics. In addition, the ALD process has demonstrated a very low density of pinhole defects, a requirement for building a reliable EL device using an ITO top electrode.

AMEL IC Design

The active matrix circuitry is fabricated on silicon-on-insulator (SOI) wafer substrates. SOI wafers provide the isolation required between the high voltage ac waveform of the EL device and the low voltage digital signals used to address each pixel. A schematic drawing of the layout for the active matrix circuitry of an AMEL display is shown in Figure 9. Each pixel contains a gating transistor, a storage capacitor and a high voltage transistor. A typical EL device requires a modulation voltage which has a peak to peak value of approximately 80 volts. Therefore, the breakdown voltage of the DMOS transistor must be greater than 80 volts. Currently, DMOS breakdown voltages in excess of 120 V have been achieved by using a buried oxide thickness of 1 micron. The peripheral circuitry consists of the shift registers and line drivers required for addressing the display one line at a time.

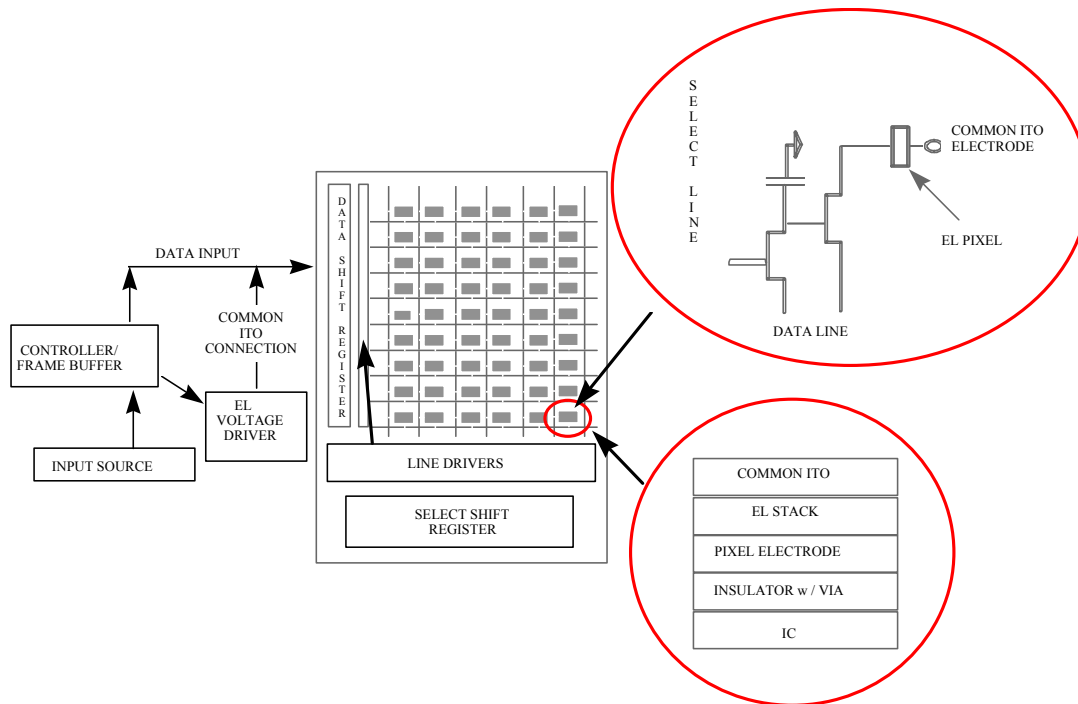

Figure 9: Diagram of AMEL Display Organization

Monochrome AMEL Displays

The first generation of AMEL displays are based on a 24 micron pixel which gives a resolution of 1000 lpi. Two monochrome displays have been developed with this resolution: a 640x480 VGA and a 1280x1024 XGA display [24, 25]. The performance characteristics for the 0.76 inch diagonal 24 micron pixel VGA display are shown in Table IV. The data inputs for this display are delivered via 8 parallel lines and six control signals using standard 5V logic levels.

Table IV: AMEL VGA Performance Characteristics

Characteristic	Parameter	Value
Dimensions	Active Area	15.5 x 10.9 mm
	External Package	20.8 x 24.1 mm
	Thickness	1.7 mm
Resolution	Matrix Format	640 x 480
	Lines per inch	1000 lpi
Color	Yellow	580 nm
Brightness	Areal	250 nits
Contrast	Ratio	100:1
Display Power		0.5 W
Interface Electronics		2.7 W
Gray Scale	5 Bits	32 levels
Weight		3 grams

The luminance of 250 nits is sufficient for most applications, however, for see-through HMD applications where the image is superimposed on a bright ambient scene, a higher brightness is needed. By using an optimized ZnS:Mn device structure and increasing the number

of illumination pulses per frame, luminance levels in excess of 2500 nits have been achieved for these VGA displays.

A second generation of AMEL displays using a 12 micron pixel has recently been developed that extends the resolution of AMEL technology to 2000 lines per inch. The first device developed using the 12 micron pixel was a 0.76 inch diagonal 1280x1024 display [26]. This high resolution AMEL display operates at a higher data rate of 100 MHz in order to load the data in the 60 Hz frame time. The 12 micron pixel design provides lower power and lower cost than the 24 micron pixel designs for the same display format.

Color AMEL Displays

Figure 10 shows a diagram of the two basic approaches that have been investigated to achieve color AMEL: a spatial patterned filter approach and a temporal frame sequential color approach. Both approaches use the broad band white EL phosphor (SrS:Ce/ZnS:Mn) in combination with either a patterned color filter or a color shutter. The patterned color filter approach may ultimately provide the best efficiency because a higher percentage of the light is transmitted through the color filters than through a liquid crystal color shutter.

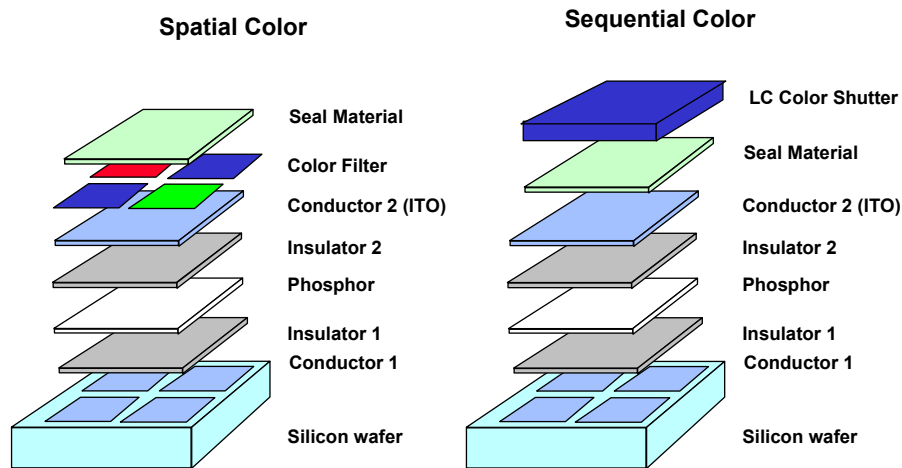

Figure 10: Color AMEL Display Structures

One challenge for a high resolution spatial color AMEL display is the light piping in the thin films which results in a desaturation in the chromaticity. To reduce the effects of light piping, an internal black matrix and an enhanced blue pixel design was used in the design of an 0.38" diagonal color QVGA microdisplay [27]. An analog AMEL driving technique with pixel design shown in Figure 11 was used to achieve 256 gray levels per primary color. An additional advantage of the analog active matrix driving method for the AMEL microdisplay is that RGB data can be directly written row-by-row onto the display without need for a frame buffer. This results in a simple low power, low cost electrical interface. The performance specifications for this color analog QVGA AMEL display are listed in Table V.

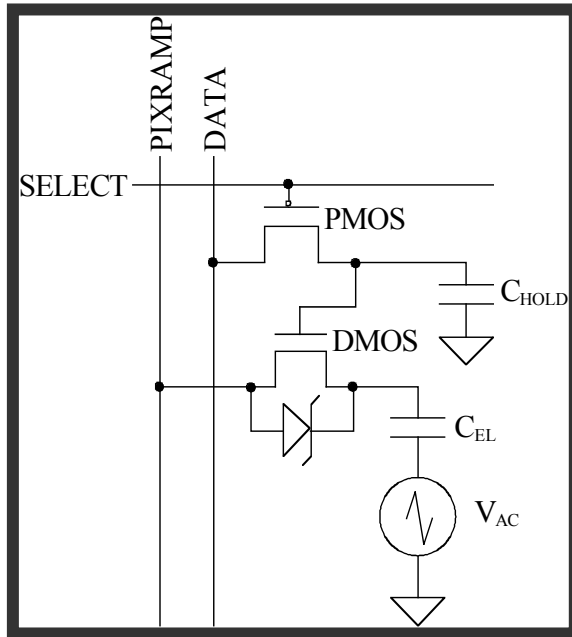

Figure 11: Analog AMEL Pixel Design

Table V. Performance Specifications for a 0.38” Spatial Color QVGA AMEL Display

Specification	Values
Pixel Format	320 (x3) x 240
White Pixel Pitch	24um x 24um
Viewable Area	7.7 x 5.8 mm
External Package (LxW)	12.1 x 16.8 mm
Thickness	2.1 mm
Weight	0.7 g
Pixel Fill Factor	57%
EL Excitation Amplitude	140 to 200V
EL Excitation Frequency	5.25 kHz
White Luminance	75 cd/m ²
Color Coordinates: Red	x = 0.60, y = 0.36
Green	x = 0.31, y = 0.58
Blue	x = 0.14, y = 0.24
Display Power Consumption	Video: 230 mW
Contrast Ratio	> 200:1
Operating Temperature	-40 to 70 C
Storage Temperature	-40 to 85 C

This spatial color QVGA AMEL has a white color temperature of 6500 °K and achieves good RGB color coordinates. Further improvement in luminance and color performance is expected in the future with the implementation of the SrS:Cu blue EL emitter into the multilayer SrS:Cu/ZnS:Mn phosphor.

TRANSPARENT TFEL DISPLAYS

Introduction

Transparent displays find use in applications where space is constrained and there is a need to provide the users with a dual set of information. For example the idea to use a transparent TFEL display in front of the analogue meters in the car dashboard has been known for some years [28]. This concept is used in certain Toyota and Lexus car models. These transparent TFEL displays are manufactured by DENSO Corporation [29]. Transparent TFEL displays can also be found in game applications. In addition, transparent displays enable exciting designs for both professional and consumer use e.g. in applications where the transparent display helps the viewer to localize objects behind the screen, or adds superimposed warning or messages on top of other information displays.

TFEL technology provides unique opportunities to realize a transparent, rugged and reliable light emitting graphic display that maintains excellent readability both in extreme temperatures and in different lighting conditions.

Transparent TFEL Device Structure

The cross-section structure of a monochrome TFEL panel is schematically illustrated in Figure 12. The film stack is deposited on substrate glass. Transparent ITO column electrodes are deposited and patterned first. Subsequently the insulator – ZnS:Mn – insulator film stack is grown. These first processing steps are identical to those of the conventional TFEL displays. However, instead of metallic row electrodes, transparent electrodes of ITO complete the film structure. Finally a glass plate is laminated on top for mechanical and humidity protection.

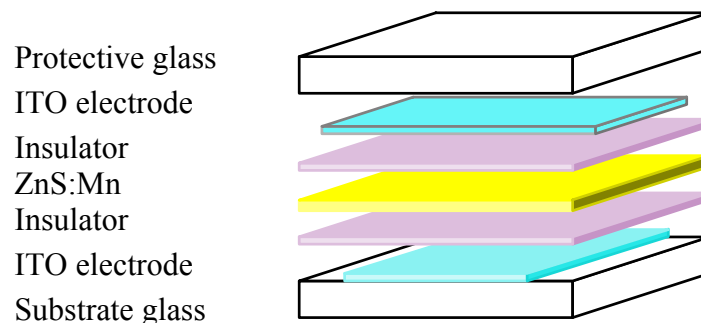

Figure 12: Schematic Diagram of Transparent TFEL Structure

The Atomic Layer Deposition (ALD) process has been exclusively employed for deposition of the insulator layers of transparent TFEL displays because of the excellent conformal coating characteristics, and very low density of pinhole defects. These characteristics are required for building a reliable TFEL device using an ITO top electrode.

Transparent TFEL Display Operating Characteristics

The luminance-voltage (L-V) characteristics of a typical transparent, ZnS:Mn based, TFEL device are similar to conventional TFEL displays with absorbing metal electrodes [30]. In order to maximize the visual performance of transparent TFEL display, optical design of the panel

structure needs to be optimized. Without optimized design, a phenomenon called “halo” decreases the visibility of the display, by causing the area around the light emitting pixels to blur. “Halo” occurs because the emitted light, which is reflected on the boundary between glass and air, scatters at the boundary of the EL layer. By optimizing the film structure, the “halo” effect can be minimized [31]. In some applications, also a light-absorbing filter is added to the panel structure. The light absorbing filter enables a “totally” black design when the display is off, e.g. in an automotive cluster with a transparent TFEL display on top of the conventional instrument display.

REFERENCES

1. M.J. Russ and D.I. Kennedy, "The Effects of Double Insulating Layers on the Electroluminescence of Evaporated ZnS:Mn Films," J. Electrochem. Soc., 114, p. 1066, 1967.
2. P.M. Alt, "Thin Film EL Devices: Device Characteristics and Performance," Proc. of the SID, 25, No. 2, p. 123, 1984.
3. T. Minami, S. Tanaka, Y. Kuroi and T. Maeno, "Thin Film Electroluminescent Devices Using Zn₂SIO₄:Mn-ZnGa₂O₄:Mn Multicomponent Oxide Phosphors", Proc. 16th Int. Display Research Conf., Birmingham, p. 215, 1996.
4. T. Xiao, A. H. Kitai, G. Liu and A. Nakua, "Bright Green Oxide Phosphors for EL Displays", SID 97 Digest, p. 414 1997.
5. R.T. Tuenge & J. Kane, "Bright Red EL Using a Thin-Film Filter," Digest of 1991 SID Int'l Symposium, p. 279, 1991.
6. T. Yosioka, Y. Sano, K. Nakamura, C. Tani, "Characteristics of Red Electroluminescence Devices Using CaS_{1-x}Se_x:Eu Phosphor Layers", SID 89 Digest, p. 313, 1989.
7. H. Ohnishi and F. Mohri, "Efficient Green-Emitting TFEL with Sputtered ZnS:TbOF", SID 92 Digest, p. 363, 1992.
8. W.A. Barrow, R.E. Coovert and C.N. King, "Strontium Sulfide: The Host for a New High Efficiency Thin-Film EL Blue Phosphor," Digest of the 1984 SID Int'l Display Symposium, p. 249, 1984.
9. K. O. Velthaus, B. Hüttel, U. Troppenz, R. Herrman, R. H. Mauch, "New Deposition Process for Very Blue and Bright SrS:Ce,Cl TFEL Devices", Digest of 1997 SID Int'l Display Symposium, p. 411, 1997.
10. X. Wu, "Multicolor Thin-Film Ceramic Hybrid EL Displays", Proc. Of 1997 Int'l Display Workshop, p. 593, 1997.
11. W.A Barrow, R.C. Coovert, E. Dickey, C.N. King, C. Laakso, S.S. Sun, R.T. Tuenge, R. Wentross, & J. Kane, "A New Class of Blue TFEL Phosphors with Applications to a VGA Full-Color Display," Digest of 1993 SID Int'l Display Symposium, p. 761, 1993.
12. S. S. Sun, E. Dickey, J. Kane and P. N. Yocum, "A Bright and Efficient New Blue TFEL Phosphor", Proc. 17th Int. Display Research Conf., Toronto, p. 301, 1997.
13. S. S. Sun, "Blue Emitting SrS:Cu TFEL Phosphor Development", Workshop Digest of Technical Papers, 1998 Asia Display and 18th Intl. Display Research Conference, p. 275, 1998.
14. N. Miura, M. Kawanishi, H. Matsumoto, and R. Nakano, Jpn. J. Appl. Phys., 38, L1291, 1999.
15. D. Seale and X. Wu, Proc. 6th Intl. Display Workshop, p. 861, 1999.

16. M. Susukida, et al., "Filter-Less Full Color Inorganic EL Display", Proc.of the 9th Intl. Display Workshops, p.911, 2002.
17. S. Tanaka, H. Yoshiyama, J. Nishiura, S. Ohshio, H. Kobayashi, "Bright White-Light EL Devices with New Phosphor Thin Films Based on SrS," Proc. Soc. Inf. Display 29, p. 305, 1988.
18. T. Nire et al., "Multicolor TFEL Display Panel with a Double Heterointerface-Structured Active Layer", SID 92 Digest, p. 352, 1992.
19. K. Ohmi, S. Tanaka, Y. Yamano, K. Fujimoto, H. Kobayashi, R.H. Mauch, K.O. Velthaus, H.W. Schock, "White Light Emitting Electroluminescent Devices with (SrS:Ce/ZnS:Mn)_n Multilayer Thin Films," Japan Display, p. 725, 1992.
20. M. Leppänen, G. Härkönen, A. Pakkala, E. Soininen, R. Törnqvist, "Broadband double layer phosphor for an inverted filtered RGB electroluminescent display," EuroDisplay, p. 229, 1993.
21. E. Soininen, et al., Proc. 7th Int. Workshop on Electroluminescence, Beijing, 1994.
22. S.S. Sun, et al., "White Monochrome TFEL Displays with SrS:Cu,Ag/ZnS:Mn Stack Phosphor", SID 99 Digest, p. 1146, 1999.
23. T. Harjue, et al., "Bright 320(x3).240 RGB Display Based on Color-by-White", SID 97 Digest, p. 859, 1997.
24. M. Aguilera, et al., "640 x 480 Active Matrix Electroluminescent Display", Proc.of the SPIE, Helmet Mounted Displays, 1996.
25. R. Khormaei, et al., "A 1280 x 1024 Active-Matrix EL Display", SID 95 Digest, p.891, 1995.
26. L. Arbuthnot, et al., "0.7-inch 1280 x 1024 Active Matrix Electroluminescent Display using a 12 um Pixel Structure", Proc. of the SPIE, Helmet Mounted Displays, 1997.
27. R. Tuenge, et al., "An Improved Analog Color AMEL Microdisplay" SID 02 Digest, p. 1025, 2002.
28. P.M. Knoll, B. Herzog, R. Sybrichs, Electronics Displays 97 Konferenzband, ISBN: 3-924651-54-X, p. 65 (1997)
29. Technical Report – Denso Technology 2001 – Instrument Clusters
http://www.globaldenso.com/TECHNOLOGY/tec-report/2001/pdf/T2001_S19.pdf
30. Mika Antikainen, Juhani Haaranen, Jorma Honkala, Marja Lahonen, Veli-Matti Liias, Arto Pakkala, Tuomas Pitkanen, Erkki Soininen, and Runar Tornqvist, "Transparent Emissive Thin-Film Electroluminescent Display", SID 00 DIGEST, p. 885, (2000).
31. S. Kanda, "Reduction of Halo in Transparent Electroluminescent (EL) Display", SDI 00 DIGEST, p.881, (2000).