



EL160.120.39
EL Small Graphics Display

USER'S MANUAL

www.planar.com

Contents

EL160.120.39 Display	2
Features	2
Installation and Handling.....	3
Mounting EL Displays	3
Cable Length.....	3
Cleaning	4
Avoiding Burn-In	4
Specifications	4
Power.....	4
Data and Power Connector	5
Generating Grayscales.....	6
Interface Information.....	6
<i>Video Input Signals</i>	6
Self-Test Mode.....	7
Optical	8
Dimming	8
Environmental.....	9
Reliability.....	9
Safety and EMI Performance	9
Mechanical Characteristics	10
Component Envelope	10
Description of Warranty	12
Ordering Information	12
Support and Service.....	12
Figures	
Figure 1. Data/Power Connector	5
Figure 2. Video Input Timing Diagram.	6
Figure 3. Pixel Location versus Sequence of Data.....	7
Figure 4. Display Dimensions.....	11
Tables	
Table 1. DC Input Voltage Requirements.	4
Table 2. Video Input Requirements.	5
Table 3. Connector Pinouts.	5
Table 4. Video Input Descriptions	7
Table 5. Optical Characteristics.	8
Table 6. Dimming Rates	8
Table 7. Environmental Characteristics.....	9
Table 8. Mechanical Characteristics.....	10

EL160.120.39 Display

The EL160.120.39 thin film electroluminescent (EL) display is a high visual performance small graphic display that excels in a wide range of ambient lighting environments. The EL160.120.39 utilizes Planar's proprietary Integral Contrast Enhancement (ICE™) technology to achieve unparalleled image quality without the use of filters or temperature compensation.

The display module consists of an EL glass panel and control electronics assembled into a space-saving, rugged package for easy mounting and includes an integrated DC/DC converter. The EL160.120.39 is easily interfaced using standard 4-bit LCD control signals. Each of the pixels has an aspect ratio of 1:1 and is individually addressable to clearly display high information-content graphics and text.

Features and Benefits

- Excellent visual performance:
 - High brightness and contrast
 - Wide viewing angle > 160°
- Rapid display response < 1 ms
- Space efficient mechanical package
- Low EMI emissions
- Extremely rugged and durable
- Reliable, long operating life: >50,000 MTBF
- 4-bit LCD-type interface

Installation and Handling

Do not drop, bend, or flex the display. Do not allow objects to strike the surface of the display.

CAUTION: The display uses CMOS and power MOS-FET devices. These components are electrostatic sensitive. Unpack, assemble, and examine this assembly in a static-controlled area only. When shipping, use packing materials designed for protection of electrostatic-sensitive components.

CAUTION: To prevent injury in the event of glass breakage, a protective overlay should be used on the viewer side of the display.

Mounting

Properly mounted, EL displays can withstand high shock loads as well as severe vibration found in demanding applications. However the glass panel used in an EL display will break if subjected to bending stresses, high impact, or excessive loads.

Avoid bending the display. Stresses are often introduced when a display is mounted into a product. Ideally, the mounting tabs of the display should be the only point of contact with the system. Use a spacer or boss for support; failure to do so will bend the display and cause the glass to break. The instrument enclosure or frame should not flex or distort in such a way that during use the bending loads might be transferred to the display. Mounting surfaces should be flat to within ± 0.6 mm (± 0.025 "). Use all the mounting holes provided. Failure to do so will impair the shock and vibration resistance of the final installation.

The EL160.120.39 is a tab mounted display. Use appropriate length standoffs to assure that screws through the mounting tabs do not introduce bending stresses into the display. Do not deflect the circuit board out of its normal plane.

WARNING: These products generate voltages capable of causing personal injury (high voltage up to 230 V_{ac}). Do not touch the display electronics during operation.

Cable Length

A maximum cable length of 600 mm (24 in.) is recommended. Longer cables may cause data transfer problems between the data transmitted and the display input connector. Excessive cable lengths can pick up and source unwanted EMI. There are techniques which allow this maximum cable length to be exceeded. Contact Planar Application Engineering for more information.

Cleaning

As with any glass or coated surface, care should be taken to minimize scratching. Clean the display glass with mild, water-based detergents only. Apply the cleaner sparingly to a soft cloth, then wipe the display. Disposable cleaning cloths are recommended to minimize the risk of inadvertently scratching the display with particles embedded in a re-used cloth. Particular care should be taken when cleaning displays with anti-glare or anti-reflective films.

Avoiding Burn-In

As with other light emitting displays, displaying fixed patterns on the screen can cause burn-in, where luminance variations can be noticed. Use a screen saver or image-inversion technique to avoid causing burn-in on the display.

Specifications

The EL panel is a matrix structure with column and row electrodes arranged in an X-Y formation. Light is emitted when an AC voltage of sufficient amplitude is applied at a row-column intersection. The display operation is based on the symmetric, line-at-a-time data addressing scheme. Performance characteristics are guaranteed when measured at 25°C with rated input voltage unless otherwise specified.

Power

The supply voltages are shown in Table 1. All internal high voltages are generated from the display supply voltage (V_H). The logic supply voltage (V_L) should be present whenever video input signals or V_H is applied. The minimum and maximum specifications in this manual should be met, without exception, to ensure the long-term reliability of the display. Planar does not recommend operation of the display outside these specifications.

Any combination or sequencing in the application or removal of V_L, V_H, or video signals will not result in abnormal display operation or display catastrophic failure.

Table 1. DC Input Voltage Requirements.

Description	Symbol	Min	Typ	Max	Absolute Max	Units
Input voltage (nom=12.0V)	V _H	8		18	19	Vdc
Input voltage (nom=5.0V)	V _L	4.75		5.25	6.0	Vdc
12V Input current (V _H =12.0V)	I _H max			0.35		Adc
5V Input current (V _L =5.0V)	I _L max			0.10		Adc
Power consumption 5 V/12 V @ max. frame rate			3.0		3.9	W

CAUTION: Absolute maximum ratings are those values beyond which damage to the device may occur.

Table 2. Video Input Requirements.

Description	Min	Max	Units	Notes
Absolute Input Voltage Range	-0.5	$V_H + 0.5 V$	V	$V_{I_{max}}$
Video logic high voltage	70%	100%	V	V_{IH}
Video logic low voltage	0%	20%	V	V_{IL}
Video logic input current	-10	+10	μA	I_{IL}

All data signal inputs are LC-filtered (lowpass, -3db at ca 13 MHz) CMOS. See information about current-limiting circuit for safety on page 9.

Data and Power Connector

The EL160.120.39 uses the 20-pin, 2-mm locking connector, Samtec EHT-110-01-S-D. The mating connector is the Samtec TCSD family of cable strips. Compatibility with non-Samtec equivalents should be verified before use.

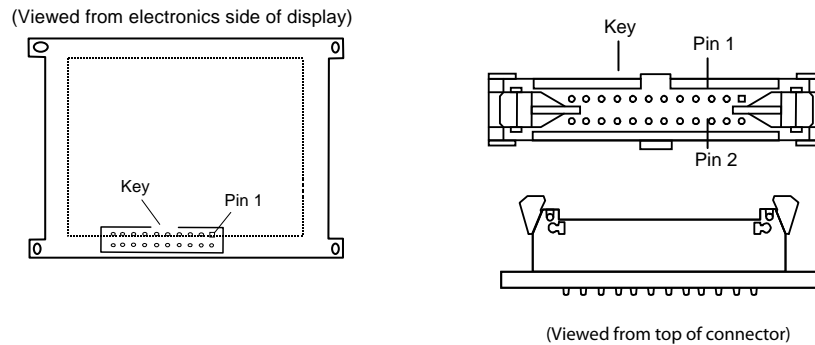

Figure 1. Data/Power Connector.

Table 3. J1 Connector Pinouts.

Pin	Signal	Description	Pin	Signal	Description
1	V_H	+12 V Power	2	V_H	+12 V Power
3	Selftest	Selftest Input ¹	4	LUM	Luminance Control
5	V_L	+5 V Power	6	GND	Ground
7	VS	Vertical Sync	8	GND	Ground
9	HS	Horizontal Sync	10	GND	Ground
11	VCLK	Video Clock	12	GND	Ground
13	VID ₀	Video Data	14	GND	Ground
15	VID ₁	Video Data	16	GND	Ground
17	VID ₂	Video Data	18	GND	Ground
19	VID ₃	Video Data	20	GND	Ground

¹ Connect pin 3 to ground for normal display operation.

Generating Grayscales

The EL160.120.39 is a monochrome display but will display dithered grayscale when driven by a suitably-equipped video controller. See Application Note 119 for more information.

Interface Information

Planar EL Small Graphics Displays (SGD) incorporate an interface that is similar to many LCD modules. This interface is supported by a variety of off-the-shelf chip sets which take care of all display control functionality, freeing the system processor for other tasks. This 4-bit LCD-type video interface provides a low cost, flexible method for controlling display brightness and power consumption.

Video Input Signals

The end of the top line of a frame is marked by **VS**, vertical sync signal as shown in Figure 2. The first pixel of each row is marked by the falling edge of **HS**. The first 160 pixels, or 40 clocks, after the falling edge of **HS** will be visible on the display.

The **VS** signal is active high. It may be independently set to a CMOS low level at any time for longer than one frame period. During the time of **VS** inactivity the display is blank. Halting **VS** results in a standby condition to minimize power consumption. Input signals **VID3** through **VID0** contain the video data for the screen. Pixel information is supplied from left to right and from top to bottom four pixels at a time.

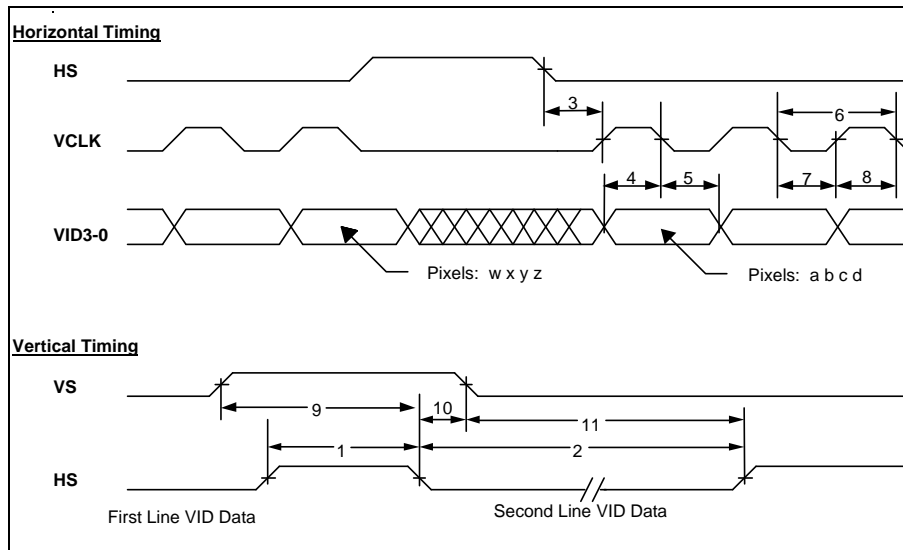

Figure 2. Video Input Timing Diagram.

Timing is compatible with LCD graphics controllers such as the SED 1335.

Table 4. Video Input Descriptions.

Num	Description	Symbol	Min.	Typ.	Max.	Units
1	HS high time	tHSh	100			nsec
2	HS low time	tHSl	40			tVCLK
3	HS to VCLK rise	tHSsu	95			nsec
4	VID setup to VCLK	tVIDsu	50			nsec
5	VID hold from VCLK	tVIDhd	50			nsec
6	VID clock period	tVCLK	140			nsec
	VCLK rise, fall time	tVCLKrf		10	15	nsec
7	VCLK low width	tVCLKl	60			nsec
8	VCLK high width	tVCLKh	60			nsec
9	VS high setup to HS low	tVShsu	140			nsec
10	VS hold after HS	tVShd	140			nsec
11	VS low setup to HS high	tVSlSu	140			nsec
12	HS period	tHS	52			µsec
	VS period	tVS	121			tHS
	Frame Rate	fVS	0		150	Hz

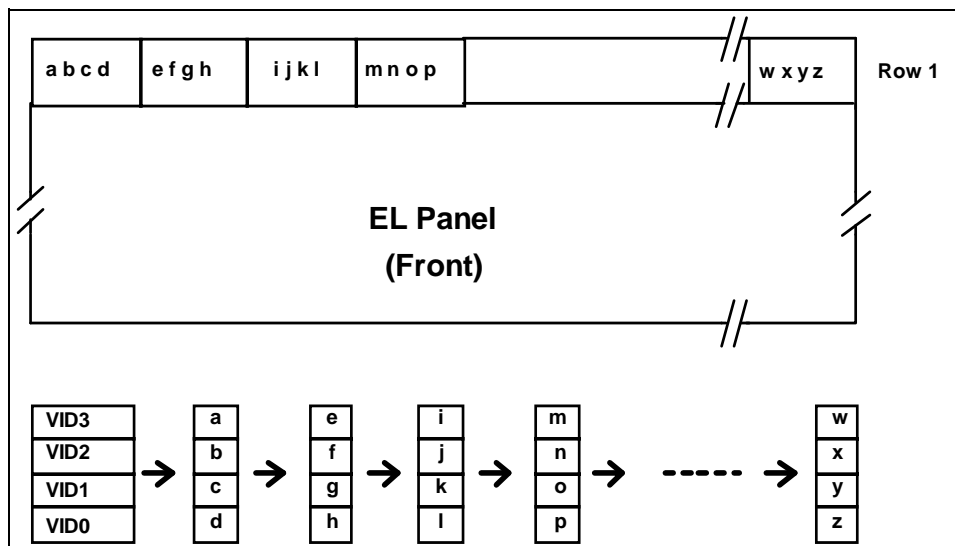

Figure 3. Pixel Location versus Sequence of Data.

Self-Test Mode

The display incorporates a self-test mode composed of two patterns displayed for approximately one minute each, and then repeated. The patterns are as follows: Full On and 1 x 1 Checkerboard. The self-test mode is entered at power on until two VS signals are detected or when pin 3 is pulled high. For normal operation the SELFTEST pin must be connected to GROUND.

Optical

Table 5. Optical Characteristics.

Luminance		
L_{on} (areal), min	50 cd/m ²	screen center, 150 Hz frame rate
L_{on} (areal), typ	70 cd/m ²	screen center, 150 Hz frame rate
L_{off} (areal), max	0.3 cd/m ²	5 points: center plus four corners measured 10±2 mm from display edges, 150 Hz
Non-uniformity		
All pixels fully lit	25%	Maximum difference between two of five points, using the formula: LNU%=[1- (min_lum/max_lum)] x 100
Luminance Variation (Temperature)		
Maximum	±20%	Across operating temperature range @120 Hz
Luminance Variation (Time)		
Maximum	<20%	10,000 hours at 25°C ambient @ 120 Hz
Viewing Angle		
Minimum	>160°	
Contrast Ratio		
Typical	59:1	@ 500 lux ambient, max frame rate
	32:1	@ 1,000 lux ambient, max frame rate
	4.3:1	@ 10,000 lux ambient, max frame rate

Dimming

Analog dimming is available on the EL160.120.39 display by connecting a 50K(ohm) logarithmic external potentiometer to the dimming port. Alternatively an external voltage or current-mode D/A converter may be used to dim the display by sinking a 0-250 μA current at 4-0 voltages respectively from the control pin to ground. For information on controlling display brightness by frame rate, please refer to Planar Application Note 120.

Table 6. Dimming Rates.

Resistance	Dimming
Maximum (No resistor connected)	100% (Default)
Maximum (50 K ohm resistor connected)	95%
Minimum (0 ohm resistor connected)	5% maximum
Values are measured as a percentage of full On Luminance	

Environmental

Table 7. Environmental Characteristics.

Temperature	
Operating	-50°C to +70°C
Operating Survival	-50°C to +85°C
Non-operating	-60°C to +105°C
Humidity	
Non-condensing, operating	93% RH max @ 40°C, per IEC 68-2-3
Condensing, Non-operating	95% RH max @ 55°C, per IEC 68-2-30
Altitude	
Operating	0 to 18,000 m (58k ft) per IEC 68-2-13
Vibration	
Operating	Random vibration test performed for 30 minutes on each axis, flat frequency profile, per IEC 68-2-36, Test Fdb. Test range is 20-500 Hz at 0.02g ² /Hz.
Shock	
Operating	100 g, 6 ms duration, half sine wave, 3 shocks on each of 6 surfaces per IEC 68-2-27, test Ea.
Thermal Shock	
Non-operating	Lower -45 °C, upper +85 °C. Dwell time 30 min., transition time < 3 min. Number of cycles 5. Per IEC 68-2-14.

Reliability

The display demonstrates MTBF greater than 50,000 hours at the maximum frame rate with a 90% confidence level at 25°C.

Safety and EMI Performance

The display module will not prohibit the end product from obtaining EN61010-1 certification. Creepage distance on the PCB will be according to EN61010 table D.18 pollution degree 2 wherever possible. Clearance will be 0.2 mm.

The display will be UL1950 recognized. The display module will not inhibit the end product from obtaining EN55022 B certification.

The display is provided with a current-limiting circuit in the DC/DC converter to ensure safety in the case of a short circuit between a high voltage and +5 V circuitry.

Mechanical Characteristics

Display External Dimensions		
millimeters (inches)	width	93.6 (3.68)
	height	61.5 (2.42)
	depth	20.0 (0.78)
<hr/>		
Weight (typical)	65g nominal	
<hr/>		
Fill Factor	59% nominal	
<hr/>		
Display Active Area		
millimeters (inches)	width	62.3 (2.45)
	height	46.7 (1.83)
	diagonal	77.86(3.07)
<hr/>		
Pixel Size		
millimeters (inches)	width	0.30 (0.012)
	height	0.30 (0.012)
<hr/>		
Pixel Pitch		
millimeters (inches)	width	0.39 (0.015)
	height	0.39 (0.015)
<hr/>		

Component Envelope

The component envelope shown in Figure 4 illustrates the distance components extend behind the display. Tall components do not necessarily fill this area. Planar reserves the right to relocate components *within* the constraints of the component envelope without prior customer notification. For this reason, Planar advises users to design enclosure components to be outside the component envelope.

An air gap is recommended to dissipate heat from display components. Device designers need to consider their specific system requirements to determine the necessary spacing.

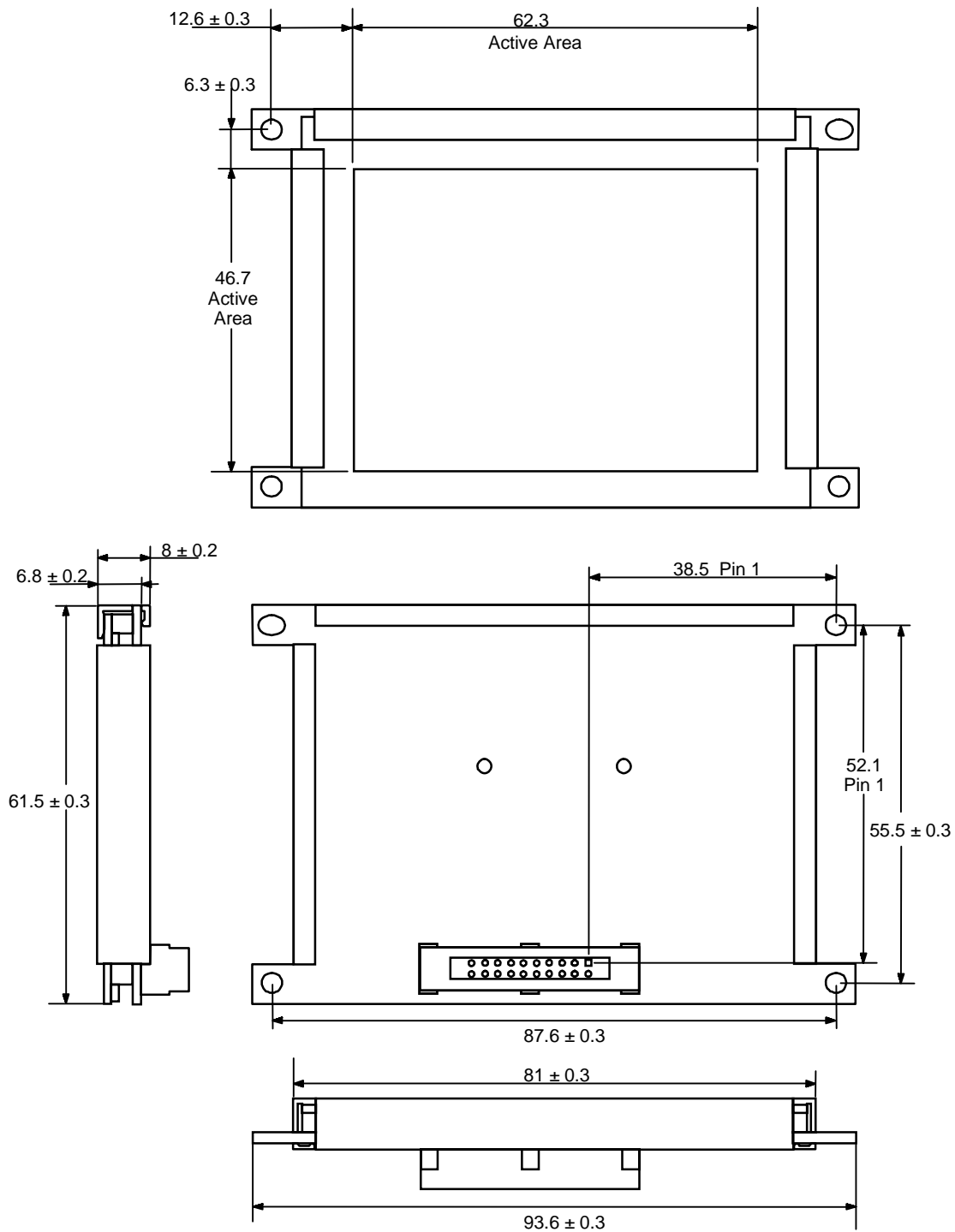

Dimensions in are millimeters.

Figure 4. Display Dimensions.

Note: This is not a controlled version of the mechanical drawing. Prior to beginning your design, please fax or email Planar Applications Engineering with the display model number and request the detailed drawing.

Description of Warranty

Seller warrants that the Goods will conform to published specifications and be free from defects in material for 12 months from delivery. To the extent that Goods incorporate third-party-owned software, Seller shall pass on Seller's licensor's warranty to Buyer subject to the terms and conditions of Seller's license.

Warranty repairs shall be warranted for the remainder of the original warranty period. Buyer shall report defect claims in writing to Seller immediately upon discovery, and in any event, within the warranty period. Buyer must return Goods to Seller within 30 days of Seller's receipt of a warranty claim notice and only after receiving Seller's Return Goods Authorization. Seller shall, at its sole option, repair or replace the Goods.

If Goods were repaired, altered or modified by persons other than Seller, this warranty is void. Conditions resulting from normal wear and tear and Buyer's failure to properly store, install, operate, handle or maintain the Goods are not within this warranty. Repair or replacement of Goods is Seller's sole obligation and Buyer's exclusive remedy for all claims of defects. If that remedy is adjudicated insufficient, Seller shall refund Buyer's paid price for the Goods and have no other liability to Buyer.

All warranty repairs must be performed at Seller's authorized service center using parts approved by Seller. Buyer shall pay costs of sending Goods to Seller on a warranty claim and Seller shall pay costs of returning Goods to Buyer. The turnaround time on repairs will usually be 30 working days or less. Seller accepts no added liability for additional days for repair or replacement.

If Seller offers technical support relating to the Goods, such support shall neither modify the warranty nor create an obligation of Seller. Buyer is not relying on Seller's skill or judgment to select Goods for Buyer's purposes. Seller's software, if included with Goods, is sold as is, and this warranty is inapplicable to such software.

SELLER DISCLAIMS ALL OTHER WARRANTIES, EXPRESS OR IMPLIED, INCLUDING BUT NOT LIMITED TO, IMPLIED WARRANTIES OF MERCHANTABILITY AND FITNESS FOR A PARTICULAR PURPOSE.

Ordering Information

Product	Part Number	Features
EL160.120.39	996-0303-00	Small graphics display with wide temperature range and dimming
EL160.120.39	996-0303-00LF	Small graphics display with wide temperature range and dimming. Meets RoHS standards

Design and specifications are subject to change without notice.

Planar Systems continues to provide optional, and in many cases custom, features to address the specific customer requirements. Consult Planar Sales for pricing, lead time and minimum quantity requirements.

Support and Service

Planar is a U.S. company based in Beaverton, Oregon and Espoo, Finland, with a world-wide sales distribution network. Full application engineering support and service are available to make the integration of Planar displays as simple and quick as possible for our customers.

RMA Procedure: For a *Returned Material Authorization* number, please contact Planar Systems, Inc. with the model number(s) and serial number(s). When returning goods for repair, please include a

brief description of the problem, and mark the outside of the shipping container with the RMA number.

European Union 2002/95/EC Directive on the Restriction of Hazardous Substances (RoHS)

In February 2003, the European Union issued Directive 2002/95/EC on the Restriction of Hazardous Substances, commonly known as RoHS, in certain electrical and electronic equipment. It restricts the use of six hazardous substances, including lead (Pb).

The Directive states that all products placed on the European market after July 1, 2006 must be compliant with its requirements.

Planar Systems Inc. is fully in support of and compliant with EU Directive 2002/95/EC on all its products, except where exempted, such as medical. Should those exemptions be removed in the future, Planar will comply with such Directives or amendments.

A Planar part number will be modified with an "LF" suffix designation to indicate RoHS compliance, as shown on the part number label affixed to the display and on the box containing the display.

Planar Systems, Inc.

Customer Service

24x7 Online Technical Support: <http://www.planar.com/support>

Americas Support

1195 NW Compton Drive

Beaverton, OR 97006-1992

Tel: 1-866-PLANAR1 (866) 752-6271

Hours: M-F, 5am - 5pm Pacific Time

Europe and Asia-Pacific Support

Olarinluoma 9 P.O. Box 46

FIN-02201 Espoo, Finland

Tel: +358-9-420-01

Hours: M-F, 7:00am - 4pm CET

© 2006 **Planar Systems, Inc. 06/06** Planar is a registered trademark of Planar Systems, Inc.

ICE, ICEBrite, and ICEPlus are trademarks of Planar Systems, Inc.

Other brands and names are the property of their respective owners.

Technical information in this document is subject to change without notice.

020-0344-00C