



SD1710

Product User's Guide

Usage Notice

- ➔ Warning To prevent the risk of fire or shock hazards, do not expose this product to rain or moisture.
- ➔ Warning Do not open or disassemble the product as this may cause electric shock.

Follow all warnings, precautions, and maintenance as recommended in this user's guide to maximize the life and performance of your unit.

Do

- Turn off the monitors before cleaning.
- Use only a dry soft cloth or cleanroom wipe when cleaning the LCD panel surface or the half-mirror.
- Use a soft cloth moistened with water and/or mild detergent to clean the display housing and stand.
- Use only safety-approved AC/DC power adapters of high quality.
- Disconnect the power plug from the AC outlet if the product is not used for a long period of time.

Don't

- Do not touch the LCD panel or half-mirror surfaces with sharp or hard objects.
- Do not use abrasive cleaners, waxes, or solvents for your cleaning.
- Do not operate the product under the following conditions:
 - Extremely hot, cold, or humid environment
 - Areas susceptible to excessive dust and dirt
 - Near any appliance generating a strong magnetic field
 - In direct sunlight

Box Contents

The SD1710 shipping box contains the following components.

	<p>Base plate, mount and locking knob</p>		<p>Bottom monitor, mount assembly, mirror support arms and mirror adjustment screws</p>
	<p>Top monitor assembly</p>		<p>Half-mirror assembly</p>
	<p>Six-foot DVI cables (2 ea)</p>		<p>Power cords (2 ea)</p>
	<p>Mirror-flip PCI card</p>		<p>One-foot DVI cable</p>
	<p>Product user's guide</p>		<p>Planar CD-ROM</p>
	<p>Terminator-style glasses (2 ea)</p>		<p>Captain-style glasses (2 ea)</p>
	<p>Spring clip-style glasses (1 ea)</p>		<p>3 mm Hex wrench</p>
	<p>Soft cloths (3 ea)</p>		<p>Moistened cleaning pads (6 ea)</p>

Contents

Usage Notice	iii
Box Contents	iv
Stereoscopic Viewing	1
Getting Started	4
Assemble the unit	4
Select a graphics card	4
Install the mirror-flip PCI card.....	5
Connect the cables	5
Connect the power cords	6
Check the alignment	6
Product Use	7
Operating in 2D mode	7
User controls and OSD menu	7
Monitor Specifications	8
Displays.....	8
Video.....	8
Power management.....	9
Plug and Play	9
Environment	9
Size and weight.....	9
System Care	9
Software Compatibility	10
Accessories	10
CRT Recycling	11
Troubleshooting	11
Warning Signals	11
Warranty	12
Product Registration	12

Stereoscopic Viewing

We live in a three-dimensional world. The human visual system can process the slightly different views of the world seen by our two eyes and translate this into the perception of depth. In the last two centuries much effort has been devoted to the reproduction of depth perception, primarily in photography and more recently in computer graphic images. Stereoscopic 3D viewing can help a viewer make faster, more accurate, and more enjoyable interpretations of imagery. The SD1710 StereoMirror™ monitor creates an unprecedented level of stereo 3D viewing quality and viewer comfort. (See Figure 1.)

Stereo viewing is useful for the following applications:

- Photogrammetry and remote sensing
- Geospatial image analysis
- Geophysical modeling
- Molecular modeling
- Computer games
- Oil and gas exploration
- Architecture and mechanical design
- Stereo photography or videography
- Medical imaging (not yet as FDA 510k approved)
- Surgical planning
- Teaching of anatomy
- Simulation
- Complex data analysis



Figure 1. The StereoMirror monitor.

→ **Warning** For some individuals, prolonged use of any stereoscopic monitor may cause discomfort.

Introduction to StereoMirror Technology

A StereoMirror™ monitor consists of two AMLCDs (Active Matrix Liquid Crystal Display) oriented at a 110° angle using a specially designed mounting stand. A passive beamsplitter mirror bisects the angle formed between the two monitors mounted on the stand. One side of the glass mirror has a reflective coating, and the other side has an anti-reflective coating to minimize secondary reflections. The mirror has a hard top coating to accommodate cleaning. There is a fine mechanical adjustment for the mirror angle between the two displays.

In general, the objective of a stereoscopic display is to efficiently present a left eye image solely to the left eye while the right eye image is directed to the right eye. This allows the human visual system to merge the two images and results in the perception of depth, or stereopsis. In the StereoMirror design, this stereo

separation is achieved using the principle of conservation of polarization. Liquid crystal displays operate based on the ability of liquid crystal material to modulate plane-polarized light. The planes of polarization for light emitted from the two AMLCDs in the SD1710 unit have

the same 45° orientation to start. The image from the lower monitor is seen through the mirror. (See Figure 2.) The plane of polarization for the light from this display is unchanged in passing through the mirror. However, the polarization plane in the light path of the upper monitor is effectively rotated 90° upon reflection. When stereo pair images from the two monitors are viewed through crossed-polarizing glasses (glasses with polarizing films mounted on the eyepieces with their planes of polarization at a right angle to one another), the user only sees the left eye image with the eyepiece having the 45°-oriented polarizer and the right eye image with the eyepiece having the 135° polarizer. Light with a perpendicular polarization is not transmitted. The result is a single, fused stereoscopic image.

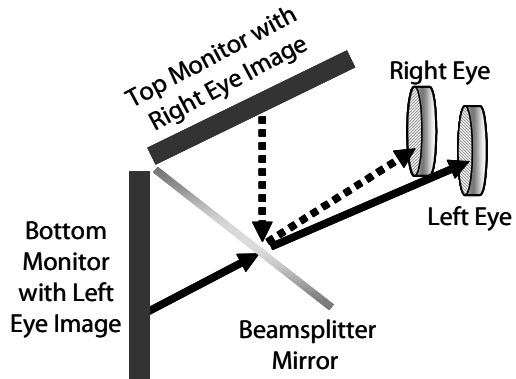

Figure 2. Operating principle of the StereoMirror monitor.

A block diagram describing the process of driving a StereoMirror monitor with a computer is shown in Figure 3. The left eye and right eye images are sent to their respective AMLCDs independently and without any special treatment. (The exception accommodates for the fact that the upper monitor is seen in a mirror. See discussion below.) Presenting the stereo pair of images is accomplished using a setup or software application that accommodates dual-monitor stereo viewing. It requires no additional modification for use with the StereoMirror monitor design. Any software application that uses the OpenGL quad-buffered stereo features is compatible with the StereoMirror monitor. Quad-buffered stereo is a feature of the OpenGL 3D graphics library that allows an application to define two separate right/left eye viewpoints instead of the normal single monoscopic viewpoint. The two viewpoints are defined to give the correct parallax separation for the proper stereo effect. Once the two viewpoints have been defined, the 3D scene is rendered identically for each of the two viewpoints. Many commercial 3D applications already have stereo viewing modes using the OpenGL stereo features.

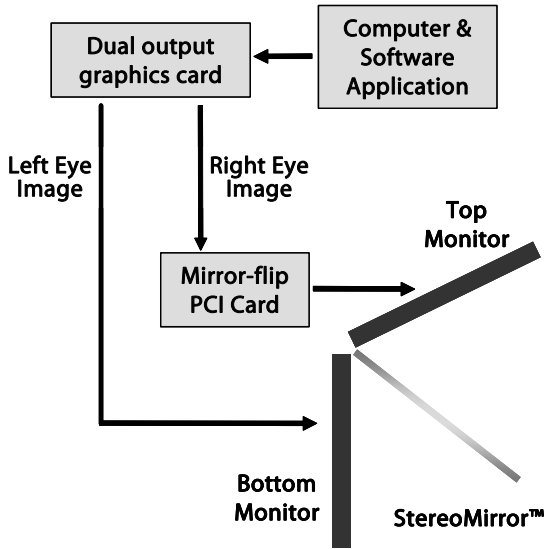

Figure 3. Driving the StereoMirror monitor.

Since the upper display in the monitor is seen in reflection, there is a need to perform a mirror-flip operation on that data path. In the current product, this is accomplished using an auxiliary signal processing board in the data path to the upper monitor. Driving a StereoMirror monitor is identical to driving a pair of projection displays used to show stereoscopic images with crossed polarizers in the two separate light paths. An off-the-shelf, dual-output graphics card is employed to drive the two monitors, with no special preparation.

For more information, visit the Planar web site at www.planar.com and refer to the paper on the StereoMirror monitor.

Getting Started

Assemble the unit

1. Remove the large black base plate with attached mounting bracket from the shipping box and place it on a table or workbench. Unscrew the large knob from the base plate mount. (See Figure 4.)
2. Remove the bottom LCD panel with attached mounting post from the shipping case and install the post in the base plate mounting bracket. Make sure that the post is fully seated against the base plate. Tighten the large knob to secure the post to the base plate.
3. Remove the top LCD panel from the shipping case and install the curved slotted post on the support bar between the two posts on the back of the bottom LCD panel. Make sure the slot is fully seated in the bottom post. Tighten the plastic handle (about ½ turn clockwise). (See Figure 5.)
4. Carefully remove the glass mirror from the shipping case. With the StereoMirror™ logo oriented to the lower right, insert the pins located on either side of the mirror frame into the corresponding slots on the mirror support arms. The pins should rest in the fully forward position of the mounting arm slots. The monitor is now ready to attach to the computer. (See Figure 6.)

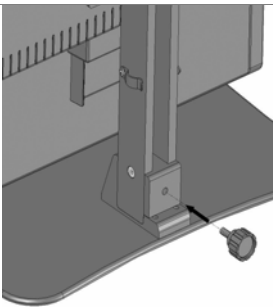

Figure 4. Knob connecting the base plate and the mounting bracket.

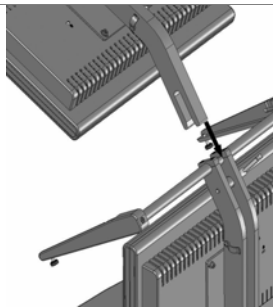

Figure 5. The Upper monitor mounting arm slides into the lower mount assembly.

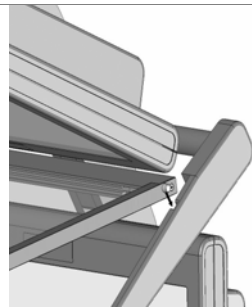

Figure 6. Glass mirror pins on each side fit into the mirror support arms.

Select a graphics card

The SD1710 unit requires an appropriate graphics card to drive the two monitors with a DVI signal. For professional applications that use OpenGL stereo support, the graphics card should support OpenGL stereo as well. Currently, Planar can recommend two graphics card families for professional applications. The Matrox® Parhelia™ line and the nVidia® Quadro™ FX line

have been tested and are compatible. For some less-demanding applications, it may be acceptable to use a less expensive, dual-DVI output graphics card.

Install the mirror-flip PCI card

Because the viewer will see a reflection of the top monitor, it is required that this image be flipped on the horizontal axis. A mirror-flip PCI card is included with the SD1710 unit. Plug this card into a free PCI slot in your computer. There are no drivers to load with the mirror-flip PCI card.

- Warning Proper ESD (electro static discharge) handling precautions should be exercised when installing the mirror-flip PCI card. Consult your computer's manual regarding the correct installation procedure for graphics cards.



Figure 7. Mirror-flip PCI card installed.

1. Remove the blank bracket from an available PCI slot.
2. Insert the mirror-flip PCI card into the slot, align the connector pins, and press the board down until it is firmly seated. (See Figure 7.)
3. Secure the mounting bracket.

Connect the cables

The SD1710 unit comes with two 6-foot DVI cables and one 14-inch DVI cable.

1. Take one of the 6-foot DVI cables and plug one end into the primary port of your dual-channel DVI graphics card (GC). Plug the other end into the bottom monitor of your SD1710 unit.
2. Plug one end of the 14-inch DVI cable into the secondary output of the dual-channel graphics card. (See Figure 8.) Plug the other end into the input port (labeled "IN") of the mirror-flip PCI card.



Figure 8. Short DVI cable installed.

3. Take the other 6-foot DVI cable and plug one end into the output port of the mirror-flip PCI card (labeled "OUT"). Plug the other end into the top monitor of your SD1710 unit.

➔ **Warning** The two monitors must be connected with an off-the-shelf video cable in order to comply with FCC regulations. Ferrite-core interface cables are provided. This device will not be in compliance with FCC regulations when a non-ferrite-core video cable is used.

Connect the power cords

Two power cords are shipped with the unit. First, plug one into the AC power jack of the top monitor. Next, plug the other into the bottom monitor. Then, plug the power connectors into an electrical outlet.

Turn on the hard power switch located on the back of the two LCD monitors.

Turn on the soft power switch located on the front bezel of the two LCD monitors.

You can now power up the computer.

Check the alignment

Although the SD1710 unit is aligned during manufacturing, it may require realignment due to shipping and/or routine handling. There are two fine adjustment screws located on the mirror support arms. Rotating these screws raises and lowers the half-mirror. Adjust the screws so that the corners of the reflected image of the upper monitor are aligned with the corners of the transmitted image from the lower monitor. You may want to use a test image during the alignment process. A sample is available on the Planar web site at www.planar.com.

Perfect alignment between the two images is not required for stereo viewing. The human visual system is typically adept at "fusing" two images that shifted relative to each other. This is especially true for horizontal misalignment. In a careful manner, try to achieve vertical alignment as closely as possible. Slight misalignment to the left or right is tolerable.

Product Use

Operating in 2D mode

Your SD 1710 unit can operate either as a 3D stereoscopic monitor or in the standard 2D mode. There are two options to convert to the 2D mode.

- Simply turn off the power to one monitor.
- Lift the mirror and slide it into the locked, upright position. (See Figure 9.)

To return to 3D stereo, simply reverse the procedure.

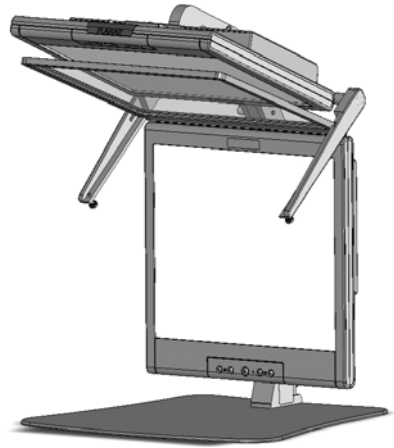

Figure 9. The StereoMirror monitor in 2D mode.

User controls and the OSD menu

The two monitors have a soft DC power switch in the center of the bottom bezel. (See Figure 10.) This control is used for turning the monitor on or off. To the right of the power switch is an LED power indicator. When the LED is green, the power is on. A yellow light indicates that the monitor is in power-saving mode. When the LED power indicator is off, the monitor power is off. The left and right Function buttons can be used to control the Onscreen Display menu selection. The left and right Adjust buttons can be used to decrease or increase the OSD setting.



Figure 10. Controls and LED indicator.

The two monitors have an OSD menu that allows control of the Brightness setting. Adjustment of the brightness is not a direct increase or decrease to the overall luminance, but a driving voltage adjustment of the LCD panel. In other words, setting the brightness to 0 (zero) does not reduce the luminance to 0 cd/m². Note that changing the Brightness setting reduces the number of discernable gray levels.

Monitor Specifications

Displays

Size	17-inch (430-mm) diagonal
Display type	Active matrix color TFT LCD panel
Resolution	1280 x 1024 (SXGA)
Display dot	1280 x (RGB) x 1024
Display area (H x V)	337.92 x 270.336 mm
Pixel pitch	0.264 mm
Brightness (2D mode with mirror raised)	260 cd/m ² (typical), 200 cd/m ² (minimum)
Brightness (Stereo 3D Mode)	70 cd/m ² (typical, through the glasses)
Contrast ratio (2D mode with mirror raised)	450:1 (typical)
Response time	12 ms (3 ms rise, 9 ms fall)
Display color palette	16.7 million colors (6 bit + FRC)
Refresh rate	56 – to 75 Hz (60 Hz recommended)
Power requirements, input voltage	Single phase, 100 – 240 VAC (50/75 Hz)
Power requirements, input current	1.2 A maximum per monitor
Power supply	Internal
Power consumption	48 W per monitor, 96W total (6 W total standby)
Lamp voltage	650 Vrms (typical)
Lamp current	7.0 mA rms (typical)
Product approvals	UL, CSA, FCC-B, CE

Video

Input signal	24-pin DVI-D, D-sub 15-pin
Input impedance	75 Ohm \pm 2%
Sync input signal	Digital TMDS, separate TTL-compatible horizontal and vertical synchronization
Polarity	Positive, negative
Multimode horizontal frequency	24 – 80 KHz
Multimode vertical frequency	49 – 75 Hz

Power management

This LCD monitor complies with the VESA DPMS (version 1.0) Power Management guidelines. The VESA DPMS provides four power-saving modes through detecting a horizontal or vertical sync signal. When the LCD monitor is in power-saving mode, the monitor screen is blank and the power LED indicator light is yellow.

Plug and Play

The unit supports the VESA DDC2B functions of Plug and Play.

Environment

Operating conditions, Temperature	5°C - 40°C (41°F - 104°F)
Operating conditions, Relative humidity	20% to 80%
Storage Conditions, Temperature	-20°C - 60°C (-4°F - 140°F)
Storage Conditions, Relative humidity	5% to 85%

Size and weight

See Figure 11 for dimensions on front and side views of the SD1710 unit.

System width	18.7 in. (474 mm)
System depth	19.5 in. (495 mm)
System height	23.3 in. (591 mm)
System weight	33 lb. (15 kg)
Monitor width	14.7 in. (373 mm)
Monitor depth	2.3 in. (58 mm)
Monitor height	14.0 in. (356 mm)
Monitor weight	11 lb. (5.0 kg)

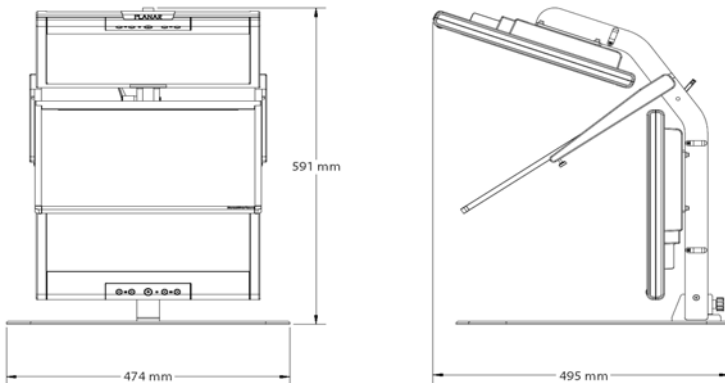

Figure 11. Dimensions, front and side.

System Care

Monitors. Turn off the monitors before cleaning. Use a dry soft cloth, cleanroom wiper, or compressed air when cleaning the LCD panel surface. A soft cloth moistened with water and/or mild detergent can be used to clean the display housing and stand. Do not touch the LCD panel surfaces with sharp or hard objects. Do not use abrasive cleaners, waxes, or solvents for your cleaning.

Mirror. Use a dry soft cloth, cleanroom wiper, or compressed air when cleaning the mirror surface. A soft cloth moistened with glass cleaner, water, and/or mild detergent can also be used to clean the mirror. Do not touch the half-mirror surfaces with sharp or hard objects. Do not use abrasive cleaners, waxes, or solvents for your cleaning.

Polarized glasses. Use a dry soft cloth, cleanroom wiper, or compressed air when cleaning the polarized glasses. A soft cloth moistened with water and/or mild detergent can also be used to clean the glasses. Do not touch the surfaces of the polarized glasses with sharp or hard objects. Do not use abrasive cleaners, waxes, or solvents for your cleaning.

Software Compatibility

OpenGL®. The SD1710 unit is compatible with OpenGL stereo. An appropriate graphics card is required to drive the two monitors with DVI signals. For professional applications that use OpenGL stereo support, the graphics card should support OpenGL stereo as well. Stereo viewing of professional applications is typically done in the so-called clone mode, where most of the same information is duplicated on the left and right monitor, except for the stereo imagery. In other words, the desktop, windows, and menus are identical, but the bottom monitor shows the left eye image while the top monitor exhibits the right eye image.

DirectX®. The SD1300 unit is compatible with the DirectX® application programming interface (API).

Accessories

For repetitive transportation of the SD1710 unit, a reusable, ruggedized shipping case is available from Planar Systems. The case features a tough plastic shell, locks, customized foam inlay, and removable wheels.

Additional polarized glasses are available from Planar in three styles: Captain, Terminator and Spring-Clip (for attaching to prescription glasses).

Contact Planar via the web site at www.planar.com or send e-mail to stereomirror@planar.com. Accessories can also be purchased through the Planar SD1710 resellers.

CRT Recycling

If your new Planar monitor is replacing a CRT, keep the following in mind:

- If the CRT is in good working condition, consider donating it to a school or non-profit organization. This may be considered a charitable tax deduction.
- Do not throw away a CRT. Cathode Ray Tubes contain hazardous materials and can not be discarded with other refuse. There are a number of recycling programs available. A quick search online for “CRT Recycling” may result in dozens of potential service providers.

Troubleshooting

Problem: No image appears on the screen

- Check that all the power cord connections are securely connected.
- Check that the power buttons on the side and front of both monitors are switched on and that the power indicator light is green.
- Check that the DVI cables are securely fastened to the graphics card, the mirror-flip PCI card, and the two monitors.
- Make sure that the pins of the DVI connectors are not bent or broken.
- If only the bottom monitor appears to be working, make sure the graphics card is not in the single-monitor mode.

Problem: Partial image or incorrectly displayed image

- Check to see if the resolution of the computer/graphics card is higher than that of the LCD panels (1280 x 1024).
- Check to see that the output timing of the video signals are within the synchronous range of the LCD panels (horizontal: 24 ~ 80 KHz; vertical: 56 ~ 75 Hz). The “Out of Range” message appears on the screen if they are not supported by the LCD panel.

Problem: Both displays work but there is no stereo functionality.

Be certain the graphics card is properly set up for the dual-monitor stereo mode. If you are using a professional application, make sure that OpenGL settings are enabled. Refer to the owner’s manual for your graphics card.

Warning Signals

A green power indicator light on a monitor means that it has a signal and is working properly.

A yellow light indicates that the monitor is in power-saving mode.

When the LED power indicator is off, the monitor power is off.

A “Check Video Cable” warning means that the monitor is powered on, but is not detecting a video signal.

Warranty

The SD1710 Standard Warranty includes an advanced replacement warranty service. Return the defective part of the system for a replacement with a comparable product.

Features

- All components have a 30-day inspection warranty period.
- All system components have a 1-year advance replacement warranty.
- Two business day delivery.
- Expedited Delivery Service available.
- Warranty Term Extensions available.

Please go to the Planar Systems, Inc. website at www.planar.com for the complete details of the warranty, including support procedure, returning a nonfunctioning unit, extended warranty limitations, and exclusion of damages.

Product Registration

To register your product, go to <http://www.planar.com/Support/cust.asp>.

Planar Systems, Inc.

Customer Service

Online Support: <http://planar.custhelp.com>

E-mail: desktopmonitors@planar.com

Telephone: 1-866-PLANAR-1 (1-866-752-6271)

Hours: Monday - Friday, 8 A.M. - 9 P.M. Eastern Time

020-0421-00A

© 2005 Planar Systems, Inc. Planar is a registered trademark of Planar Systems, Inc.

Other brands and names are the property of their respective owners.

Technical Information in this document is subject to change without notice.

01/05