



PLL1920M
LED LCD Monitor

USER'S GUIDE

www.planar.com

Content

Operation Instructions	1
Safety Precautions	2
First Setup	3
Front View of the Product	4
Rear View of the Product.....	5
Installation.....	6
Basic Operation.....	8
Advanced Operation—OSD Menu	10
Supporting Timing Modes	14
Technical Information	15
Wall-mount instruction.....	16
Care and Maintenance	17
Troubleshooting	17
Product Support	18

Operation Instructions

Thank you for purchasing this LED LCD Monitor, a high-resolution multi-scan color LED LCD Monitor. Please read this guide thoroughly before installation.

FCC RADIO FREQUENCY INTERFERENCE STATEMENT

WARNING: (FOR FCC CERTIFIED MODELS)

This LED LCD Monitor has been tested and found compliant with the limits for a Class B digital device, pursuant to part 15 of the FCC Rules. These limits are designed to provide proper protection against harmful interference to a residential installation. This LED LCD Monitor generates, uses, and can radiate radio frequency energy. Harmful interference to radio communication may be led as a result if it's not properly installed and used. However, there is no guarantee that interference will not occur in a particular installation. If this LED LCD Monitor does cause serious interference to radio or television reception, resetting the LED LCD Monitor may determine it. Moreover, users are encouraged to correct interference by doing one or more of the following:

- Reorient or relocate the receiving antenna.
- Move the LED LCD Monitor and the receiver further away from each other.
- Connect the LED LCD Monitor into an outlet on a circuit different from that to which the receiver is connected.
- Consult your local dealer or an qualified technician.

FCC Warning:

To assure a continued FCC compliance, a user must use a grounded power supply cord and the provided shielded video interface cable with bonded ferrite cores. Also, any unauthorized changes or modifications to this LED LCD Monitor would void the user's authority to operate this device.

Note: If necessary, shielded interface cables and AC power cord must be used to meet the emission level limits.



According to WEEE regulation, this LED LCD Monitor can't be handled as normal trash in Europe when it is out of usage. Please refer to the recycle information on Planar's website to handle it.

For more information on how to recycle your product, please visit WWW.PLANARSYSTEMS.COM/GREEN

Safety Precautions

This LED LCD Monitor is manufactured and tested on a ground principle that a user's safety comes first. However, improper use or installation may result danger to the LED LCD Monitor as well as to the user. Carefully go over the following WARNINGS before installation and keep this guide handy.

WARNINGS:

- ◆ This LED LCD Monitor should be operated only at the correct power sources indicated on the label on the rear end of the LED LCD Monitor. If you're unsure of the power supply in your residence, consult your local dealer or power company.
- ◆ Do not try to repair the LED LCD Monitor yourself as it contains no user-serviceable parts. The LED LCD Monitor should only be repaired by a qualified technician.
- ◆ Do not remove the LED LCD Monitor cabinet. There is high-voltage parts inside that may cause electric shock to human bodies, even when the power cord is disconnected .
- ◆ Stop using the LED LCD Monitor if the cabinet is damaged. Have it checked by a service technician.
- ◆ Put your LED LCD Monitor only in a clean, dry environment. Unplug the LED LCD Monitor immediately if gets wet and consult your service technician.
- ◆ Always unplug the LED LCD Monitor before cleaning it. Clean the cabinet with a clean, dry cloth. Apply non-ammonia based cleaner onto the cloth, not directly onto the glass screen.
- ◆ Keep the LED LCD Monitor away from magnetic objects, motors, TV sets, and transformer.
- ◆ Do not place heavy objects on the cable or power cord.
- ◆ For PLUG CABLE EQUIPMENT, the Socket-outlet shall be installed near the equipment and shall be easily accessible.
- ◆ Due to safety concerns, if the VESA mounting kit is purchased separately, please make sure the mounting kit is UL-Listed, and replaceable only by service personnel.

First Setup

Congratulation for purchasing this LED LCD Monitor of high performance!

This LED LCD Monitor comes with the following accessories:

- LED LCD Monitor
- Power Cable
- VGA Cable (15 pin)
- User's Guide
- BNC to RCA adaptor
- Base

Install the stand base

1. Lay the LED LCD Monitor flat on a table with the LCD screen face down. To prevent the monitor from being scratched, put a piece of soft cloth on the table on which the screen will be set.
2. Unpack the stand and mount it onto the base, aligning the base with the hook for the base.
3. Slide the stand upward until you hear a click, which indicates that the stand is attached and installed.
4. Stand the LED LCD Monitor up.

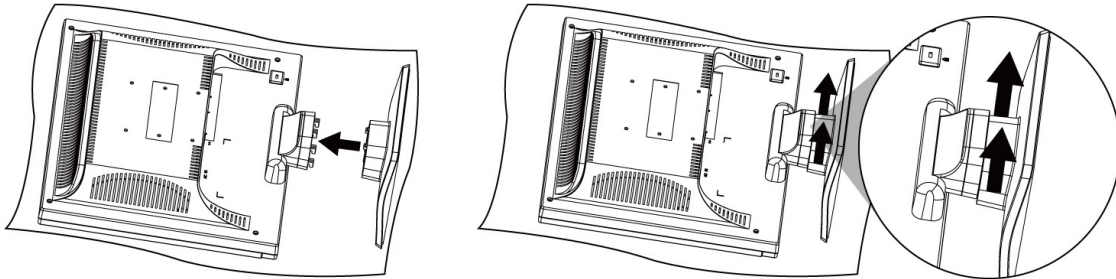

Uninstall the stand base

1. Lay the LED LCD Monitor flat on a table with the LCD screen face down. To prevent the LED LCD Monitor from being scratched, put a piece of soft cloth on the table on which the screen will be set.
2. Locate the hook at the bottom of the stand.
3. Hold down the LED LCD Monitor firmly with one hand. With the other hand, lift the hook up with your finger, do not let go. At the same time push the stand down. Make sure you slide the stand down slowly or you may damage both the LED LCD Monitor and the stand.
4. The stand will move down and is no longer installed.

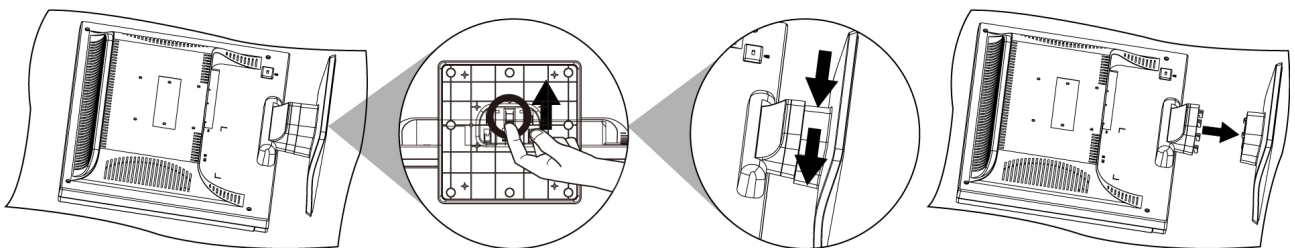

Front View of the Product



①	OSD Turn On/ Off
②	Volume Down/ Scroll Down/ Adjust Decrease
③	Volume Up/ Scroll UP/ Adjust Increase
④	Input select/ Confirm Selection
⑤	Power On/ Off and LED Indicator

Note: ▲/▼ button will be performed as volume down/ up control when OSD menu is disabled.

Rear View of the Product

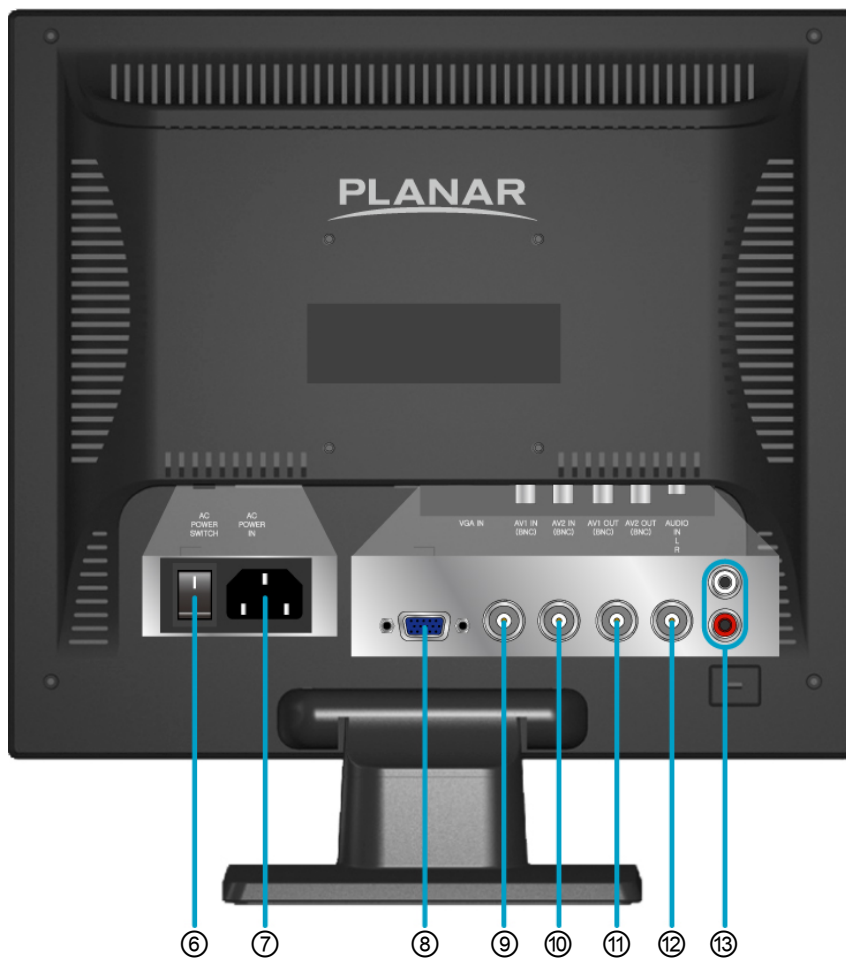

⑥	AC Power Switch
⑦	AC Power Input
⑧	VGA Input (D-Sub 15 pin)
⑨	Composite-1 Video Input (BNC)
⑩	Composite-2 Video Input (BNC)
⑪	Composite-1 Video Output (BNC)
⑫	Composite-2 Video Output (BNC)
⑬	VGA/ AV/ Signal Audio Input (Left/ Right)

Installation

Connecting to External Devices

Connect Video/ Audio cables from compatible devices into the back panel of LED LCD Monitor.

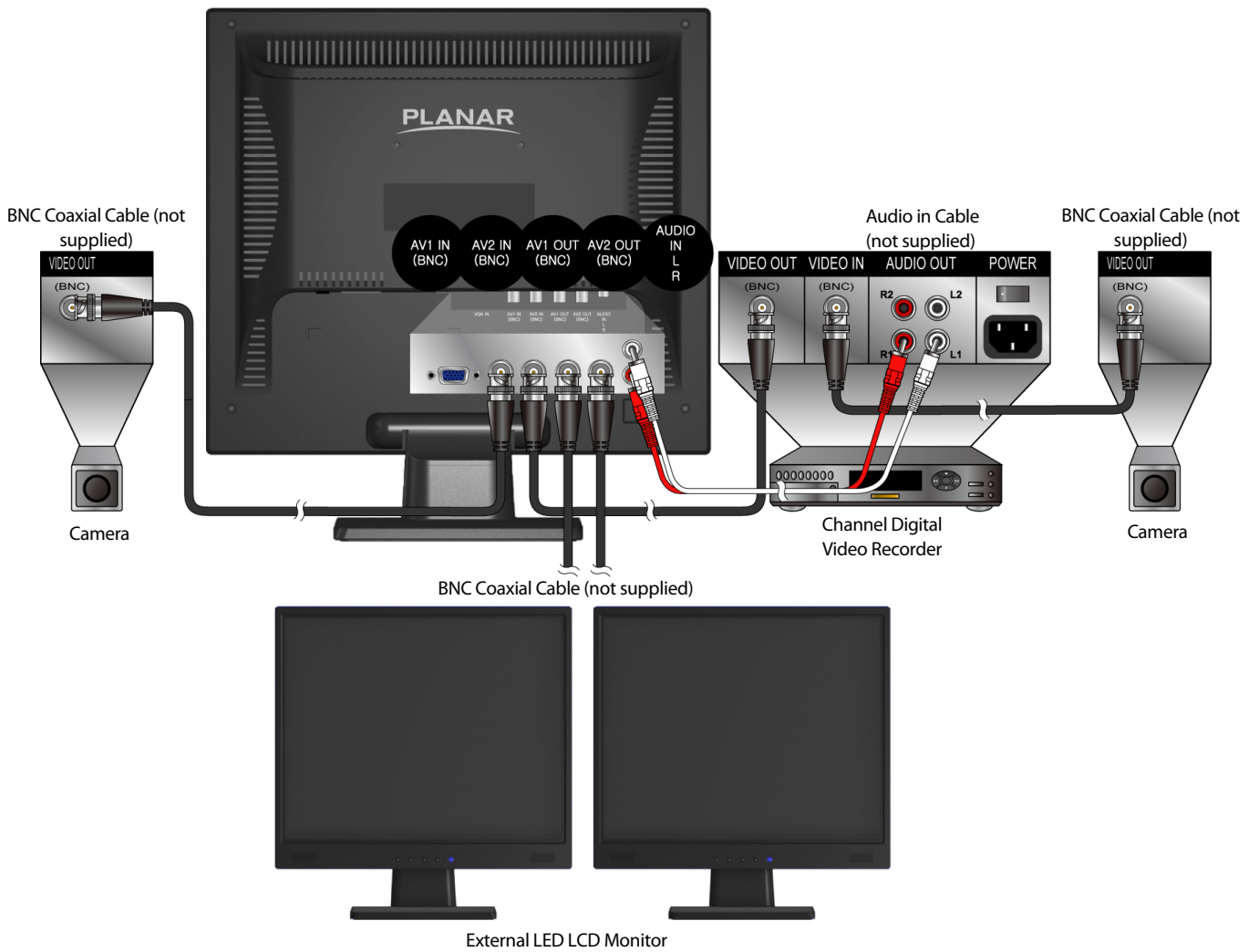

Connecting to a Computer

VGA (15pin D-Sub): Connect the VGA cable from VGA output of the computer to the VGA terminal input of your LED LCD Monitor. Also, connect the green end of the Audio In cable from the audio output of your computer to the audio input terminal (red/white) of LED LCD Monitor.

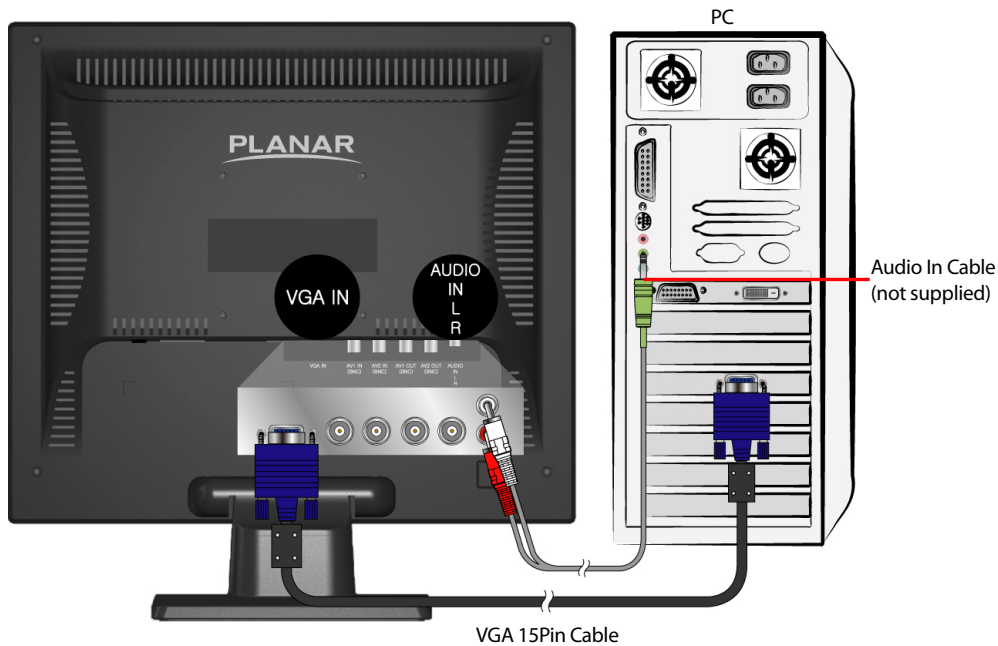

Connecting with the Power Cord

Connect the power cord to the power cord connector on the back of your LED LCD Monitor, and plug the other end of the power cord into a correctly grounded electrical outlet, and flip the main power switch on LED LCD Monitor to the ON (I) position. LED LCD Monitor will enter standby mode and the power indicator will light up orange.

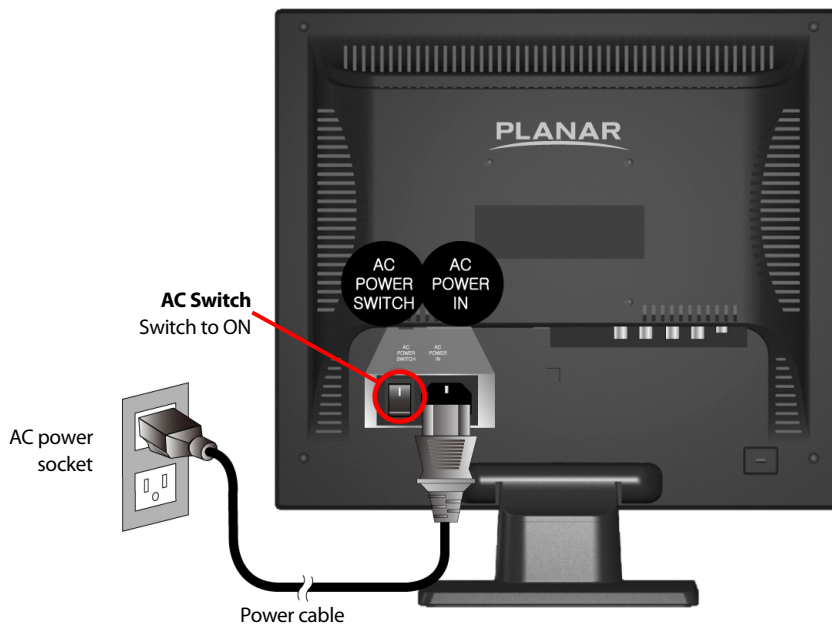

Basic Operation

Before using the LED LCD Monitor:

Connect external equipments properly.

Insert the power plug, and the power LED indicator will light orange.

Power On/Off

To turn the LED LCD Monitor on/off:

Press **POWER** button on the front of LED LCD Monitor. The power LED indicator lights blue when the LED LCD Monitor is on.

Selecting input source

Press the **2** button on the front panel, and use **▲ ▼** button to select the required input source between AV1, AV2 or PC and then press **2** to confirm.

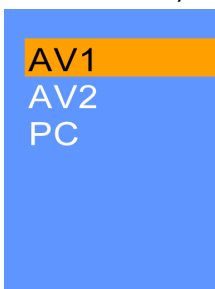

Using the OSD Menu

You are able to use OSD menus to adjust various settings by using menu button on the front of the LED LCD Monitor.

The basic operation is as following:

- Press **1** to display OSD menu.
- Use **2** to select OSD menu page.
- Press **▲ ▼** to enter the OSD menu page.
- Use **▲ ▼** to select the optional item you want to adjust.
- Press **2** to adjust levels or select the items.
- If the item is marked with **☒**, press **2** to enable the function.
- Press **1** again to exit current OSD page.

OSD Lock Out Function

When TFT LCD Monitor is in normal display, you can enable the "OSD Lock Out" function.

Option 1: OSD lock – all 4 buttons are locked except the "POWER" button.

Press and hold the **▼** button and then the **⏻** button for 3 seconds to lock the OSD buttons.

The TFT LCD Monitor will show an "OSD Lock Out" message for 5~10 seconds and the message will disappear automatically.

A screenshot of the OSD Lock out message. The text 'OSD Lock out' is displayed in yellow on a dark grey background.

OSD Lock out

Repeat this step to unlock.

Option 2: OSD & Power button lock – all 5 buttons including the “POWER” button are locked. Press and hold the ▲ button and then the ⏻ button for 3 seconds to lock all 5 buttons.

The LED LCD Monitor will show an “Lock Out” message for 5~10 seconds and the message will disappear automatically.



Repeat this step to unlock.

Advanced Operation—OSD Menu

You can use the OSD menu to adjust various settings for your LED LCD Monitor. Press the **1** button to display the OSD Menu, and use **▲▼** to select the desired OSD menu.

Picture Menu

—To adjust the picture quality

In AV1, AV2 source:

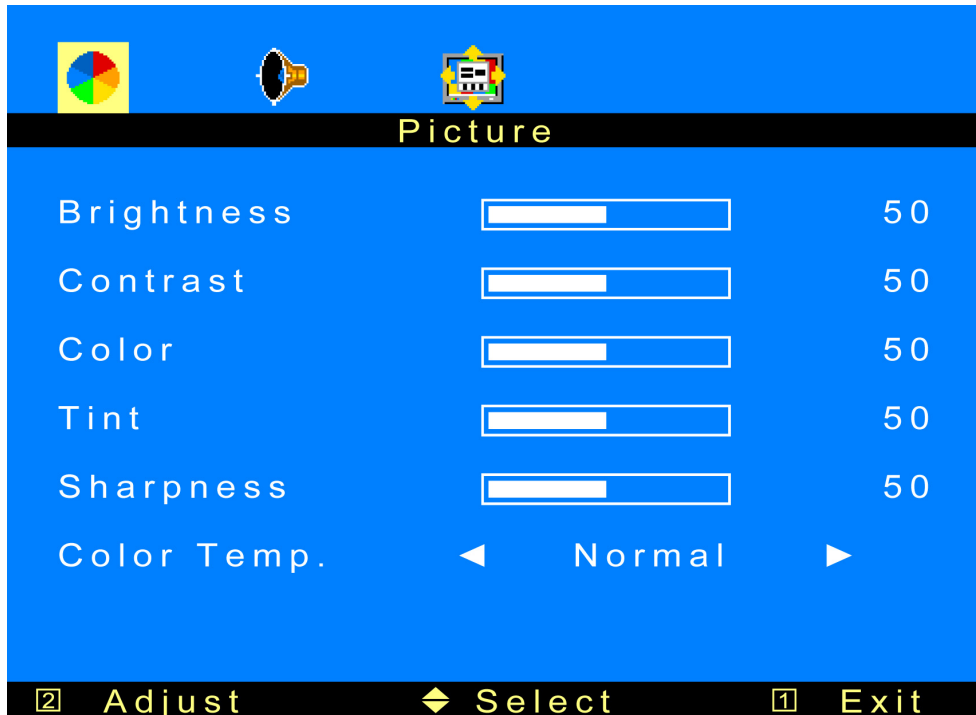

In PC source:

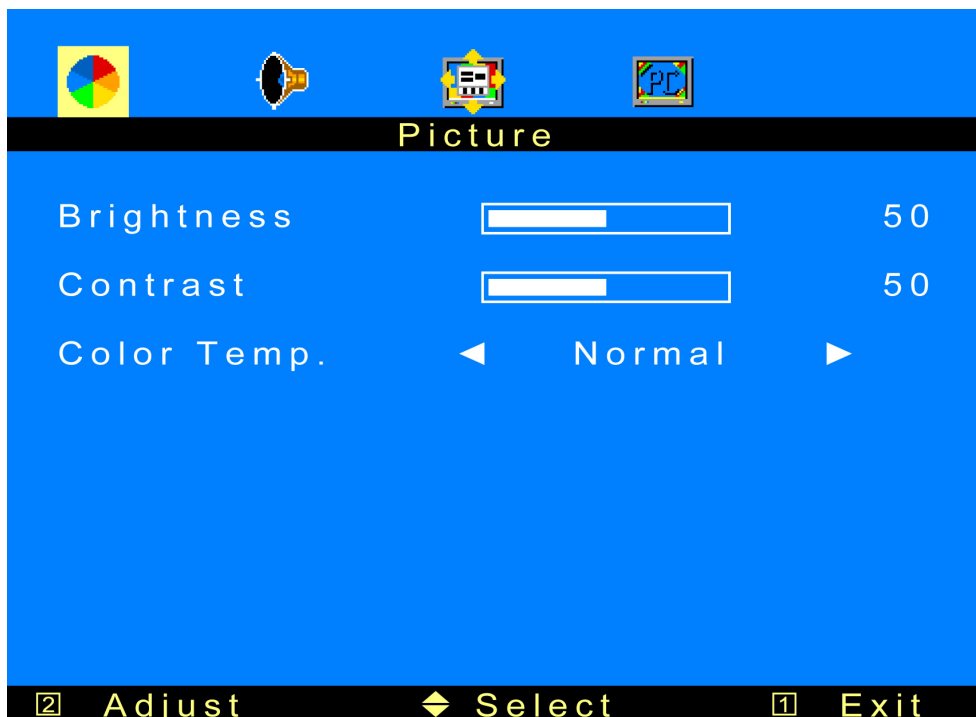

- **Brightness:** To adjust luminance of video.
- **Contrast:** To adjust contrast of video.
- **Tint:** To adjust tint level.
- **Color:** To adjust color.
- **Sharpness:** To adjust picture sharpness.
- **Color Temp.:** To select Color Temperature from Normal, Cool, and Warm with **2**.

Sound Menu

—To set the audio quality and status



Note: The PC menu icons are only enabled in PC source.

- **Bass:** To adjust the bass.
- **Treble:** To adjust the treble.
- **Balance:** To adjust the left and right audio balance.
- **Volume:** To adjust the volume.

Option Menu

—To adjust OSD setting



Note: The PC menu icons are only enabled in PC source.

- **OSD Language:** To select the OSD language between English, French, German, Spanish, Italian, Portuguese, Dutch, Swedish with **2**.
- **AV Switch:** Set the timer to 15, 30, 45, or 60 seconds will switch from AV1 source to AV2 source, or vice versa.
- **Sleep:** Set to automatically turn off the monitor. Once it is set to "ON", the monitor will be automatically turned off in 3 hours.
- **No Signal Sleep:** When this is set to "ON", the monitor will be automatically turned off after "No Signal" have been detected for 10 minutes.
- **Reset:** Press **2** to reset all the settings in OSD page.

PC Menu

—To adjust for PC

It is only active in PC source.

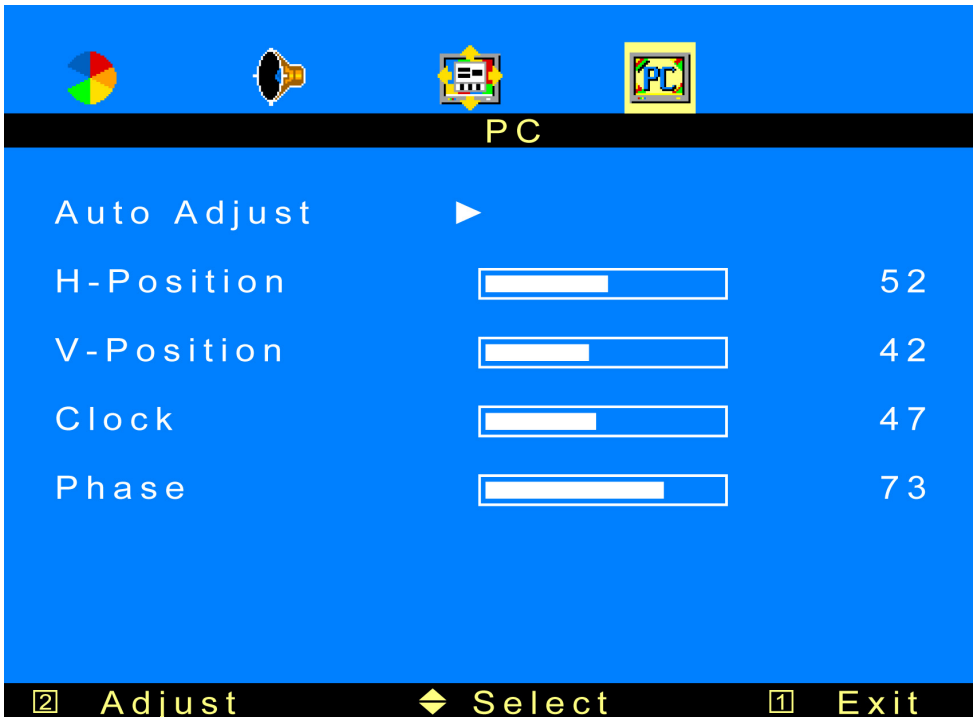

- **Auto Adjust:** To auto adjust picture's horizontal position, vertical position, fine tune and H-Size.
- **H-Position:** To adjust the horizontal position of the picture.
- **V-Position:** To adjust the vertical position of the picture.
- **Clock:** To adjust delay time of clock in order to reduce the noise of picture.
- **Phase:** To adjust delay time of phase in order to reduce the noise of picture.

Supporting Timing Modes

STANDARD	RESOLUTION
VGA	640x480 @ 60Hz
VGA	720x400 @ 70Hz
VESA	640x480 @ 72Hz
VESA	640x480 @ 75Hz
VESA	800x600 @ 56Hz
VESA	800x600 @ 60Hz
VESA	800x600 @ 72Hz
VESA	800x600 @ 75Hz
VESA	1024x768 @ 60Hz
VESA	1024x768 @ 70Hz
VESA	1024x768 @ 75Hz
VESA	1152x864 @ 75Hz
VESA	1280x960 @ 60Hz
VESA	1280x1024 @ 60Hz
VESA	1280x1024 @ 75Hz
MAC	640x480 @ 67Hz
MAC	832x624 @ 75Hz
MAC	1152x870 @ 75Hz

Note: Simultaneously press **1** and **2** keys on monitor panel to switch between similar PC timings.

Similar PC Timing on list below:

- 640 x 400 @ 70Hz / 720 x 400 @ 70Hz
- 640 x 350 @ 70Hz / 720 x 350 @ 70Hz

Warning: Do not set the graphic card in your computer to exceed these maximum refresh rates. Doing so may result in permanent damage to your LED LCD Monitor.

Technical Information

Panel	48.26 cm (19") TFT (with LED back light)
Power Management	On: 25 Watts (typical), 35 Watts (maximum) Standby Mode: < 0.5 Watt Off: < 0.5 Watt
Displayable Resolution	SXGA 1280 x 1024 max. Vertical Frequency 75Hz max.
Pixel Dimension	0.294 x 0.294 mm
Display Color	16.7M
Tilt	-1° (+/-1) ~20° (+/-2)
Active Display Area	376.32 mm x 301.06 mm
Temperature	Operating: 0°C ~ +40°C Storage: -20°C ~ + 60°C
Compliance	FCC-B, CE, UL/cUL
Power	Input Voltage AC100-240 V
Speaker	1W x 2

Wall-mount instruction

Preparing To Install The Optional Wall Mount Arm (not included)

This LED LCD Monitor can be attached to a wall mounting arm you can purchase separately.

Turn the power OFF then disconnect the cables from the LED LCD Monitor before performing the procedure below.

1. Lay the LED LCD Monitor face down on a soft surface.
2. Remove the hinge cover.
3. Remove the 4 screws holding the stand to the hinge.
4. Remove the stand.

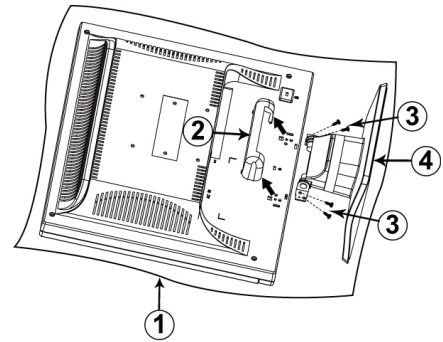

Attaching The Optional Wall Mount Arm (not supplied)

Follow these steps to finish installing the wall mounting arm:

1. Place the wall mounting arm onto the back of the LED LCD Monitor. Line up the holes of the arm with the holes in the back of the monitor.
2. Insert the 4 screws into the holes and tighten.
3. Reconnect the cables. Refer to the User's Guide that came with the optional wall mounting arm for instructions on attaching it to the wall.

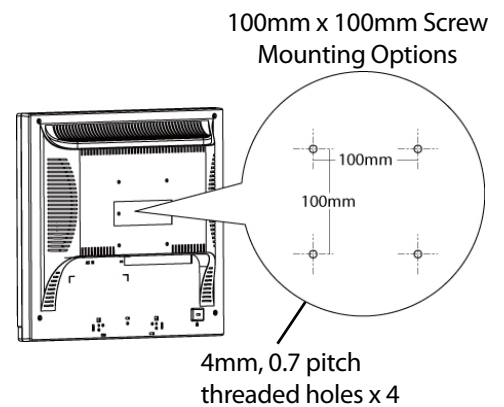

NOTE

- 100mmx100mm VESA high hole (n=4), M4, pitch =0.7 mm screw mounting kit not included.

Care and Maintenance

Care

- Avoid exposing your LED LCD Monitor directly to sunlight or other heat source. Place your LED LCD Monitor away from the sun to reduce glare.
- Put your LED LCD Monitor in a well ventilated area.
- Do not place any heavy things on top of your LED LCD Monitor.
- Make certain your LED LCD Monitor is installed in a clean and moisture-free area.
- Keep your LED LCD Monitor away from magnets, motors, transformers, speakers, and TV sets.

Note

- Move the LCD out of the package and take off the plastic bag and Polystyrene Foam.
- Pull the base from Parallel versus Panel to Vertical.
- Adjust the Panel within -1 degree leaning forward and 20 degree leaning backward. You must bend harder to exceed 20 degree backward but this range is for packing the unit to a small size for storage only.

Safety Tips

- If smoke, abnormal noise or odor came out from your LED LCD Monitor, caution you should remove the power cord immediately and call your service center.
- Never remove the rear cover of your LED LCD Monitor cabinet. The display unit inside contains high-voltage parts and may cause electric shock to human bodies.
- Never try to repair your LED LCD Monitor yourself. Always call your service center or a qualified technician to fix it.

Troubleshooting

No power

- Make sure A/C power cord is securely connected to the power adapter and the power supply is firmly connected to the LED LCD Monitor.
- Plug another electrical device into the power outlet to verify that the outlet is supplying proper voltage.
- Make sure all signal cables are installed.

Power on but no screen image

- Make sure the video cable supplied with the LED LCD Monitor is tightly secured to the video output port on back of the computer. If not, tightly secure it.
- Adjust brightness.

Wrong or abnormal colors

- If any colors (red, green, blue) are missing, check the video cable to make sure it is securely connected. Loose or broken pins in the cable connector could cause an improper connection.
- Connect the LED LCD Monitor to another computer.

Product Support

Cables, Replacement Lamps, Accessories

To find cables, replacement lamps and accessories for your Planar projector, LCD monitor, touch screen or other Planar products visit our online store at www.PlanarOnline.com or find other stores who carry Planar products at <http://www.planar.com/howtobuy>

Technical Support

Visit Planar at <http://www.planar.com/support> for product registration, operations manuals, touch screen drivers, warranty information and access to Planar's Technical Library for online troubleshooting. To speak with Planar Customer Support please have you model and serial number available and dial:

Planar Support

Tel: 1-866-PLANAR1 (866-752-6271) or +1 503-748-5799 outside the US.

Hours: 24 hours a day, 7 days a week.

Toll or long distance charges may apply.

Planar Systems, Inc.

Customer Service

24x7 Online Technical Support: <http://www.planar.com/support>

1195 NW Compton Drive

Beaverton, OR 97006-1992

Tel: 1-866-PLANAR1 (866-752-6271), or +1 503-748-5799 outside the United States,

Hours: 24 hours a day, 7 days a week

©2012 Planar Systems, Inc.

Planar is a registered trademark of Planar Systems, Inc. Other brands and names are the property of their respective owners. Technical information in this document is subject to change without notice.

2001132375T



020-1123-00B