

Disassembly Instructions

PXL2471MW LED Monitor

Last Modified: March 28, 2016

1. General Product Information

1.1 Product Description

Product Name: LED Monitor

Model Name: PLANAR PXL2471MW



2. Disassembly Assessment

2.1 Assessment Summary

Product Name / Model Name	LED Monitor / PLANAR PXL2471MW
	
Total Weight (g)	5523g
Connection Techniques	Snap Screw
Disassembly Tools	Six Point Socket Philips Screwdriver
Reuse and Recycling Rate	92.1%
Recovery Rate	98.2%

2.2 Product Derivative Table



Product Name / Model Name				LED Monitor / PLANAR PXL2471MW					
No	Item	Weight (g)	Weight (%)	Reuse (%)	Recycle (%)	Energy Recovery (%)	Disposal (%)	WEEE Annex VII(*)	Disposal Process Used after Disassembly
1	Front Bezel	131	2.4	—	2.13	0.24	0.0		Recycling
2	Back Panel	459	8.3	—	7.48	0.83	0.0		Recycling
3	Metal Fittings	1410.5	25.5	—	22.98	2.55	0.0		Recycling
4	Neck	236.5	4.3	—	3.85	0.43	0.0		Recycling
5	Stand	652	11.8	—	10.62	1.18	0.0		Recycling
6	Display Panel	2405	43.5	—	41.37	0.87	1.31	*	Selective treatment
7	PCBA	190	3.4	—	2.92	0.0	0.52	*	Selective treatment
8	Speaker	21	0.38	—	0.36	0.02	0.0		Recycling
9	Sponge	3	0.05	—	0.05	0.0	0.0		Recycling
10	Screws	15	0.27	—	0.27	0.0	0.0		Recycling
Total		5523	100.0		92.05	6.12	1.82		

*** NOTE: PCBs (printed circuit board) and LCD display panels are identified in Annex VII of European Directive 2012/19/EU as requiring special handling.**

2.3 Assessment Table

Recycling Characteristic	Result
Product Weight(A)	5523g
Reuse(B)	0g
Recycle(C)	5084.15g
Energy Recovery(D)	338.2g
Disposal(E)	100.65g
Reuse and Recycling Rate=(B+C)/A	92.1%
Recovery Rate=(B+C+D)/A	98.2%

3. Disassembly Tools

Item	Tools	Pictures
1.	Six Point Socket	
2.	Philips Screwdriver	

4. Disassembly Process

1. Exploded drawing for PXL2471MW

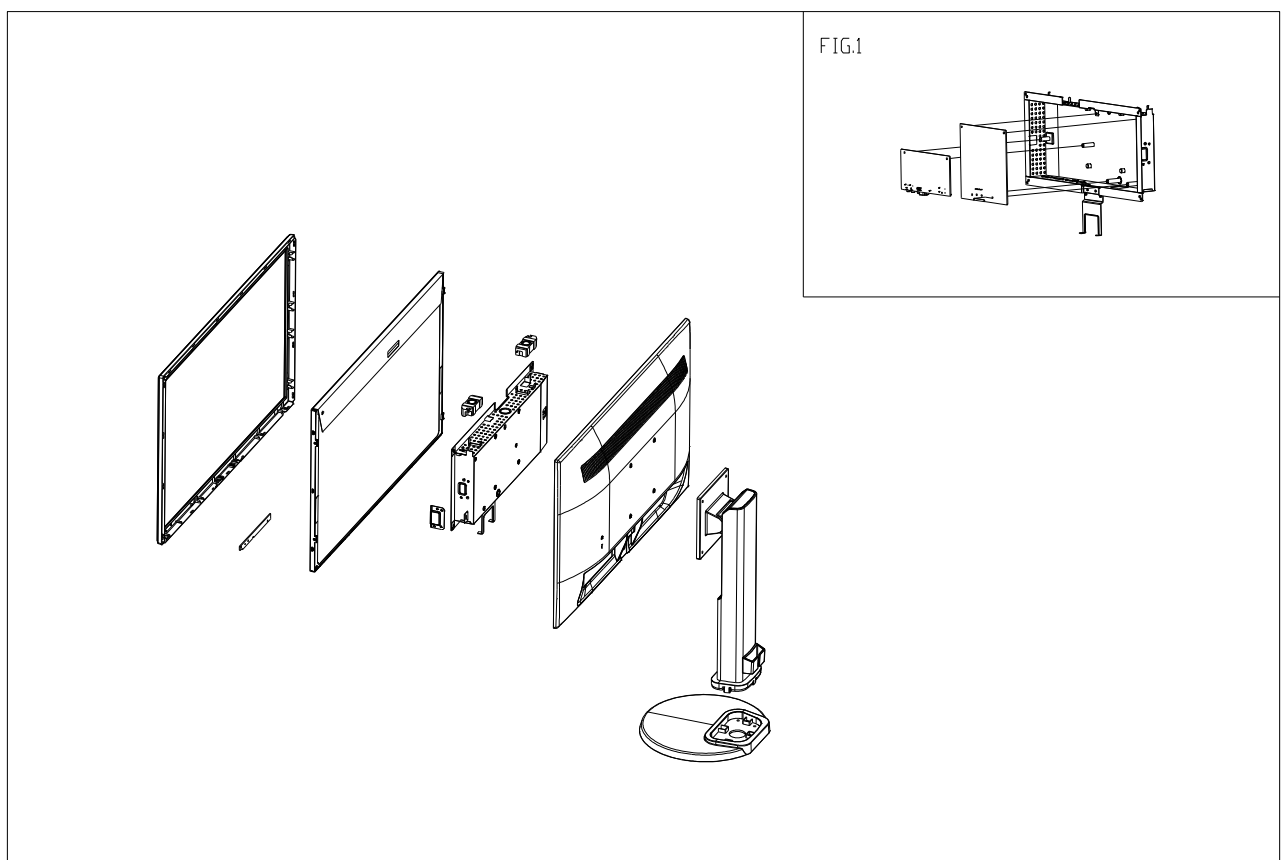

2. Remove screws to disassemble neck and stand



3. Remove back panel



4. Remove tape and the aluminum foil

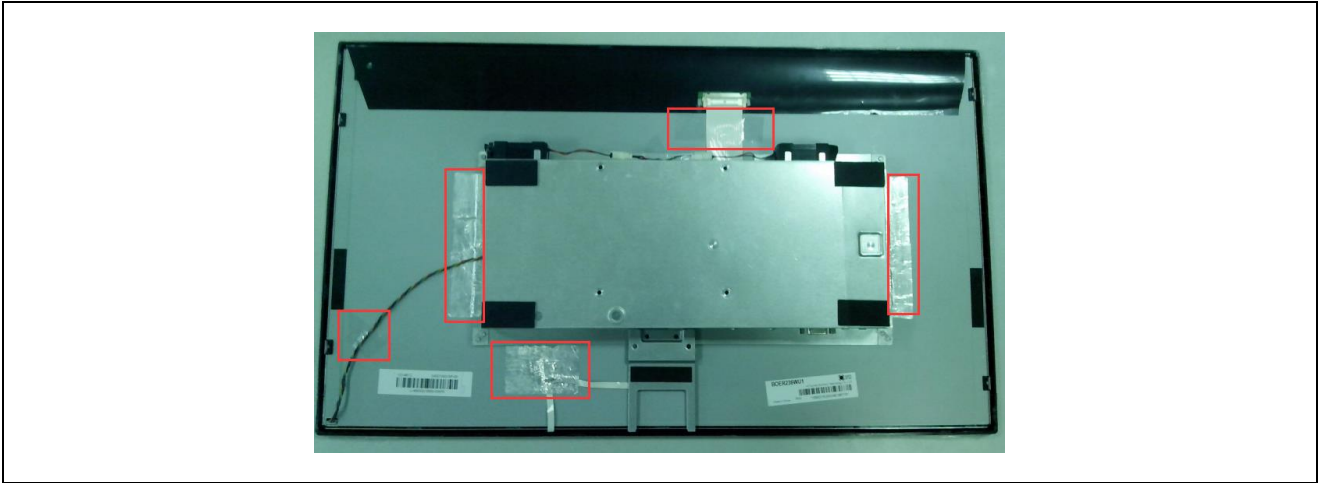

5. Remove foam tape

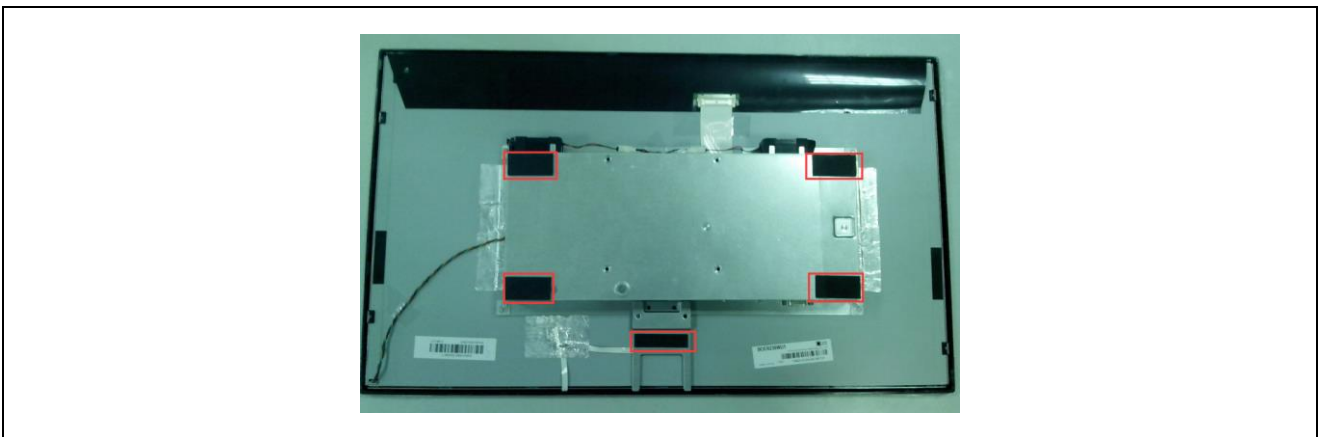

6. Disconnect the cables, and take down the shield cover

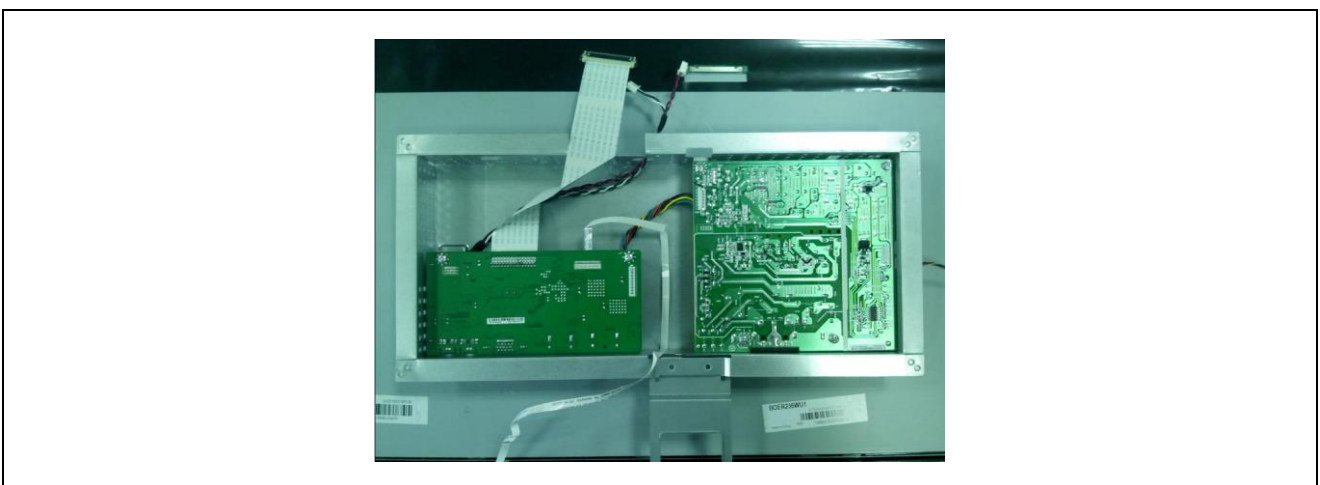

7. Remove the speakers and all related screws

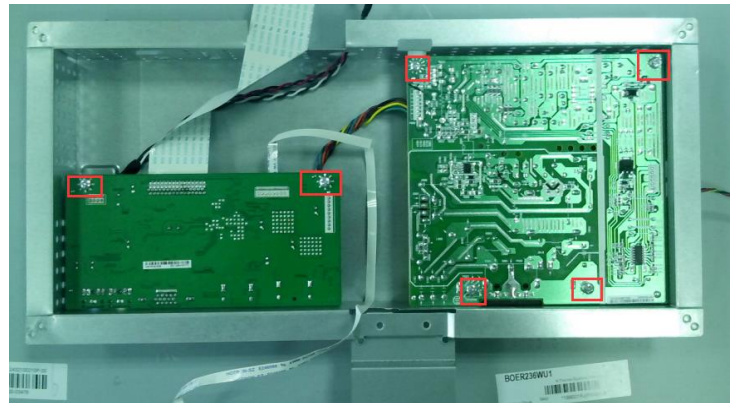
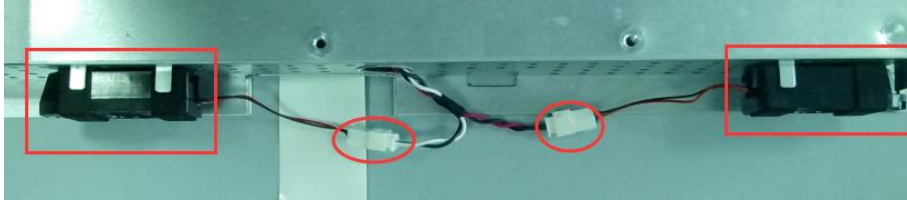

8. Disconnect cables and remove circuit boards

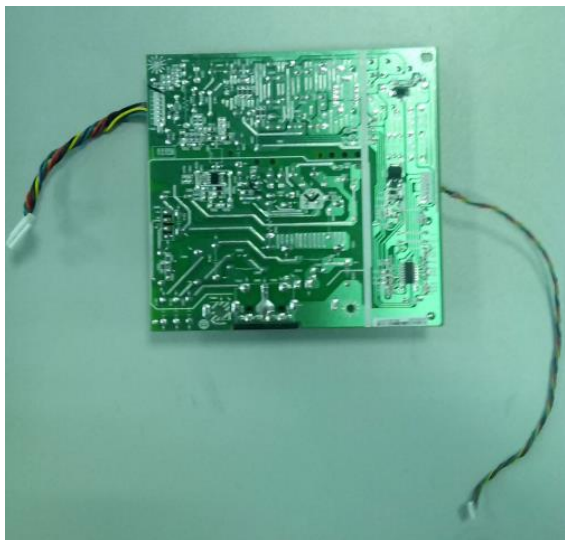
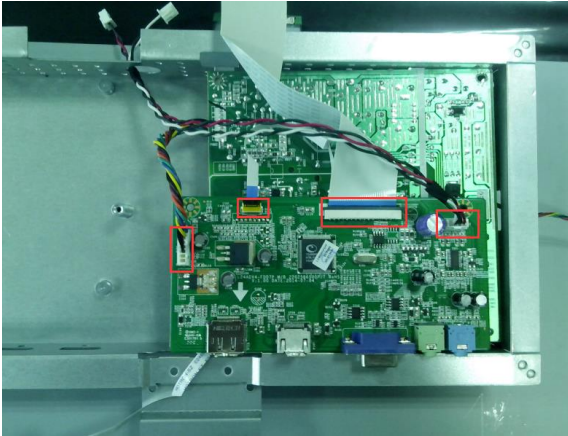

9. Take down the panel, disconnect cable, and remove circuit board

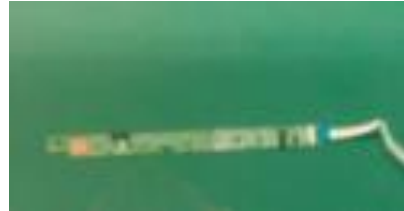

5. Disassembly Time

Total time: 20~25 minutes

6. Summary

Assessment Specification	WEEE Directive 2012/19/EU	
Annex I Classification	Category 3: IT and Telecommunications Equipment	
	WEEE Requirement	Disassembly Result
Reuse and Recycling Rate (%)	70	92.1
Recovery Rate (%)	80	98.2
Overall Result	Complies with WEEE Directive	