



PT1510MX
Touchscreen LCD Monitors

USER'S GUIDE

www.planar.com

The information contained in this document is subject to change without notice.
This document contains proprietary information that is protected by copyright. All rights are reserved. No part of this document may be reproduced, translated to another language or stored in a retrieval system, or transmitted by any means, electronic, mechanical, photocopying, recording, or otherwise, without prior written permission. Windows is a registered trademark of Microsoft, Inc. Other brand or product names are trademarks of their respective holders.

Important Recycle Instructions:

 Lamp(s) inside this product contain mercury. This product may contain other electronic waste that can be hazardous if not disposed of properly. Recycle or dispose in accordance with local, state, or federal Laws. For more information, contact the Electronic Industries Alliance at WWW.EIAE.ORG. For lamp specific disposal information check WWW.LAMPRECYCLE.ORG.

Table of Contents

Usage Notice

<i>Precautions</i>	2
--------------------------	---

Introduction

<i>About Planar's PT1510MX</i>	3
<i>Touch Screen for PT1510MX</i>	4
<i>Package Overview</i>	5

Installation

<i>Product Overview</i>	6
<i>VESA Mount your monitor</i>	9
<i>Start Your Installation</i>	10

User Controls

<i>Front Panel Controls</i>	14
<i>How to Use the OSD Menus</i>	15
<i>On-Screen Display Menus For PT1510MX Product</i>	16

Appendices

<i>Troubleshooting</i>	17
<i>Warning Signal</i>	18
<i>Product Dimensions</i>	19
<i>Compatibility Modes</i>	20
<i>Touch Screen Driver Installation</i>	21
<i>Product Registration and Technical Support</i>	24

Usage Notice

 **Warning-** To prevent the risk of fire or shock hazards, do not expose this product to rain or moisture.

 **Warning-** Please do not open or disassemble the product as this may cause electric shock.

Precautions

Follow all warnings, precautions and maintenance as recommended in this user's manual to maximize the life of your unit.

Do:

- Turn off the product before cleaning.
- Touch screen surface may be cleaned using a soft clean cloth moistened with mild window glass commercial cleaners or 50/50 mixture of water and isopropyl alcohol.
- Use a soft cloth moistened with mild detergent to clean the display housing.
- Use only high quality and safety approved AC/DC adapter that comes with your monitor.
- Disconnect the power plug from AC outlet if the product is not going to be used for an extended period of time.

Don't:

- Do not touch the LCD Display screen surface with sharp or hard objects.
- Do not use abrasive cleaners, waxes or solvents for your cleaning.
- Do not operate the product under the following conditions:
 - Extremely hot, cold or humid environment.
 - Areas susceptible to excessive dust and dirt.
 - Near any appliance generating a strong magnetic field.
 - In direct sunlight.

Introduction

About Planar's PT1510MX

The PT1510MX is a 15" flat panel screen with an active matrix, thin-film transistor (TFT) liquid crystal display (LCD).

Features include:

- ❑ Direct Analog signal input
- ❑ Active matrix TFT LCD technology
- ❑ 1024x768 XGA resolution
- ❑ 15" diagonal screen size
- ❑ 31.5 ~ 60 kHz horizontal scan
- ❑ 56 ~ 75 Hz high refresh rate
- ❑ Auto adjustment function
- ❑ Multilingual OSD user controls
- ❑ VESA DPMS power saving
- ❑ Kensington security slot
- ❑ Built-in speakers for multimedia application
- ❑ 75 mm VESA mount
- ❑ Removable base for flexible mounting solutions
- ❑ 5-wire Resistive touch screen with dual RS-232 Serial/USB controller
- ❑ Built-in Speakers – 1W/channel

Touch Screen for PT1510MX

- ❑ Analog 5-wire resistive touch screen for finger and stylus input
- ❑ Surface: Anti-glare treatment
- ❑ Interface: Dual RS-232 Serial/USB controller
- ❑ Durability: 35 million touches at a single point
- ❑ Hardness of surface: 2H MIN (As provided in JIS K 5400)
- ❑ Operating force: 0.10~1.96N(10g~200g when using a silicon tipped pen with a 3 mm radius and a hardness of 60)
- ❑ Transmissivity: 76% (Typ.)
- ❑ Driver: Supports Windows® VISTA, XP, 2000, ME, 98, NT4.0, CE, XP Embedded, Linux, Apple® Mac OS

Package Overview



LCD Display

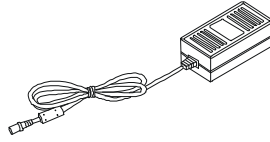

Power Adapter

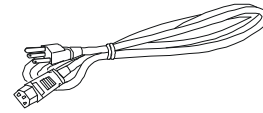

Power Cord

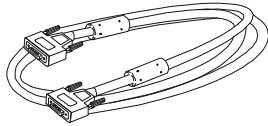

VGA Signal Cable



Audio-in Cable

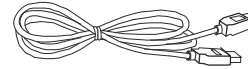

USB Cable

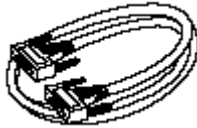

RS-232 Cable



Landing Strip

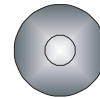

Touchscreen Driver
Installation CD-ROM



User's Guide

Installation

Product Overview

◆ Front View

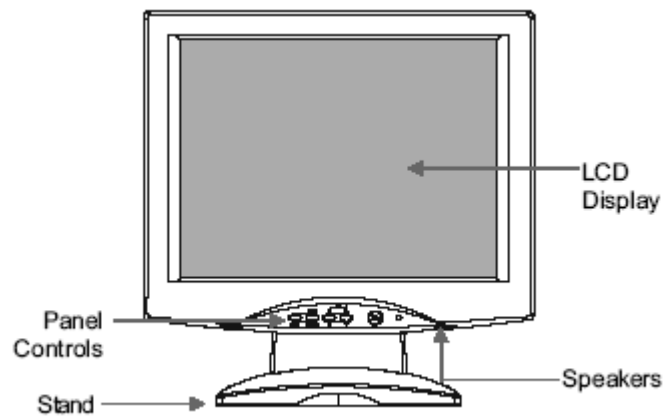

◆ Back View

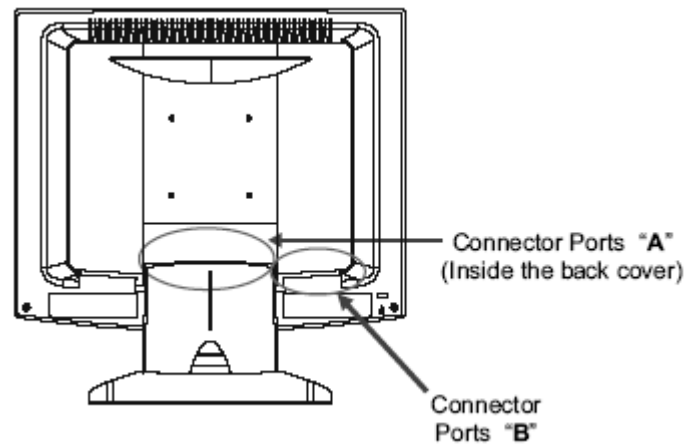

◆ Connector Ports “A”

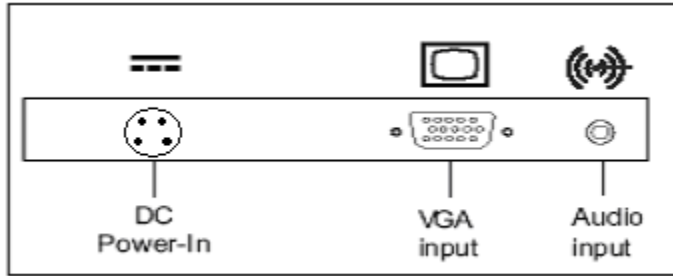

◆ Connector Ports “B”

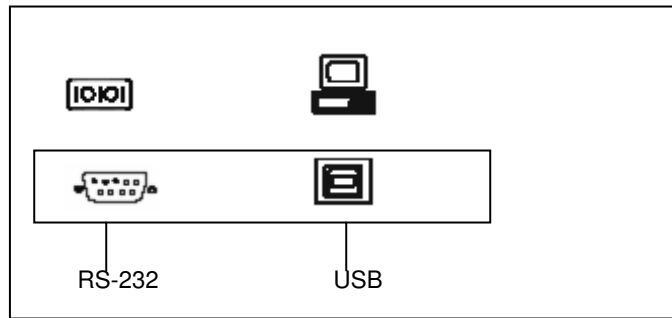

◆ Kensington Security Slot

The monitor can be secured to your desk or any other fixed object with Kensington lock security products. The Kensington lock is not included.

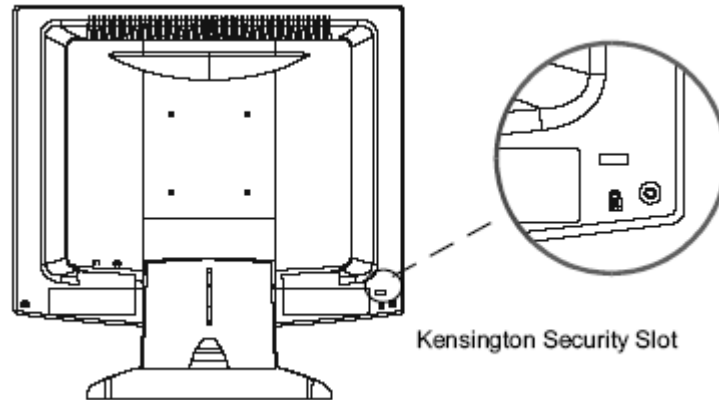

VESA Mount Your Monitor

This monitor conforms to the VESA Flat Panel Mounting Physical Mounting Interface Standard which defines a physical mounting interface for flat panel monitors, and corresponding standards for flat panel monitor mounting devices, such as wall and table arms. The VESA mounting interface is located on the back of your monitor.

To mount the monitor on a swing arm or other mounting fixture, follow the instructions included with the mounting fixture to be used.

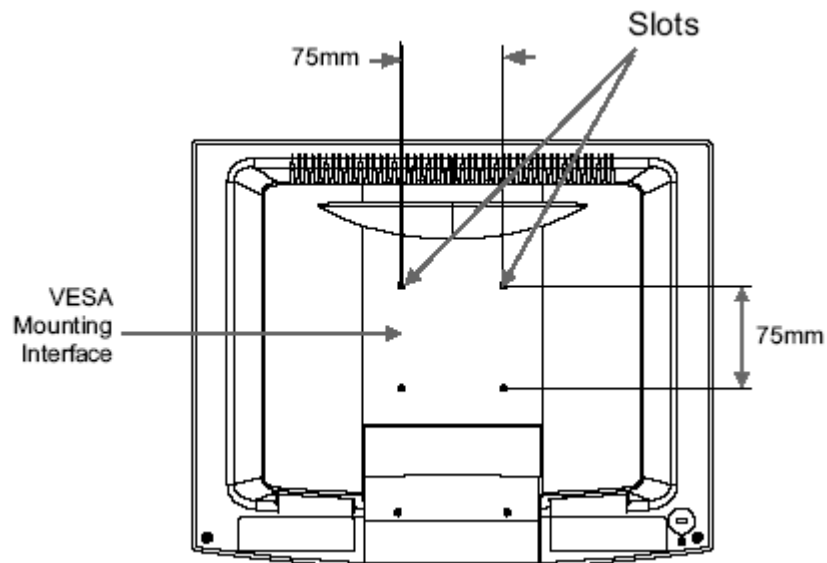

Warning!

Please select the proper screws!

The distance between the back cover surface and the bottom of the screw hole is 8mm. Please use M4 screw diameter with a maximum length of 8 mm.

Start Your Installation

◆ Remove the Back Cover

Please follow these instructions to remove the cover on the back panel of the LCD so that you can connect the cables in “Connector Ports B.”

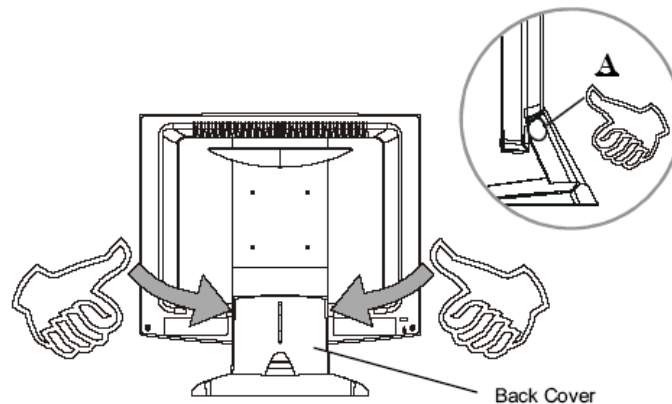

1. To remove the back cover, follow the arrows in Figure A and press with both your thumbs. The cover should be removed by pressing firmly along the edges while pulling on the cover.
2. Follow the instructions on P. 11 (Figure 11.1) to connect the cables in “Connector Ports B.”
3. Fix the cover back to the LCD by pressing firmly until the tabs snap into place. You may also keep the cables in order by using the cable organizer.

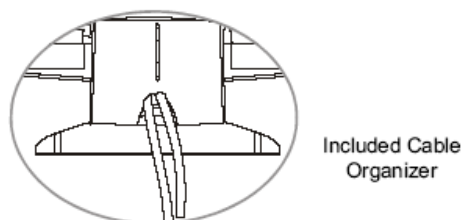

⚠ Note!

You can place the LCD flat horizontally to make it easier to connect the cables. Please make sure that you place it on an even surface lest the LCD should be damaged by scratches or collision.

◆ Connecting the Display (Figure 11.1, 11.2)

To setup this display, please refer to the following figure and procedures.

1. Be sure all equipment is turned off.
2. Connect the DC power cord to the power connector on the monitor; plug one end of the AC power cord into the power adapter, and the other end into an electrical outlet (11.1 ❶).
3. Connect the VGA signal cable from the display's VGA input connector to the 15-pin connector of your host computer and tighten the screws (11.1 ❷).
4. Connect the Audio-In cable from the audio input port of your display to the Audio-out port of your computer (11.1 ❸).
5. Configure the touch screen. Refer to the "Touch Screen Driver Installation" section on page 21.
6. Once the touch screen is configured, monitor is ready for use.

Notice!

To ensure the LCD display works well with your computer, please configure the display mode of your graphics card to make it less than or equal to 1024 x 768 resolution and make sure the timing of the display mode is compatible with the LCD display.

We have listed the compatible "Video Modes" of your LCD display in the appendix for your reference.

Figure 11.1

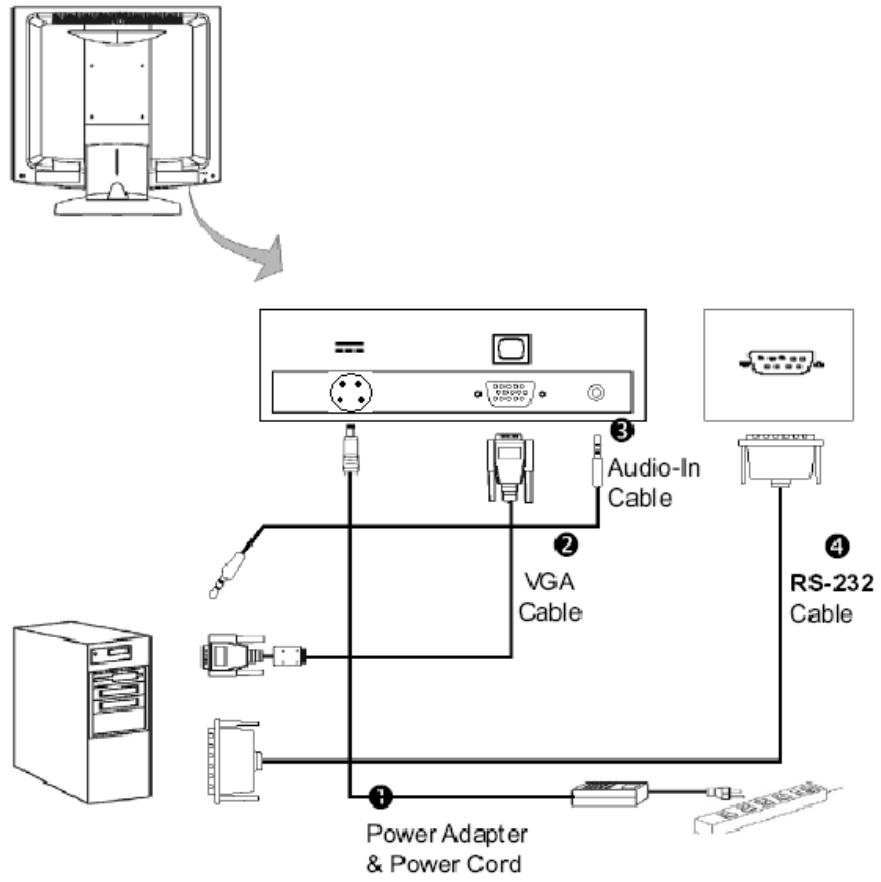
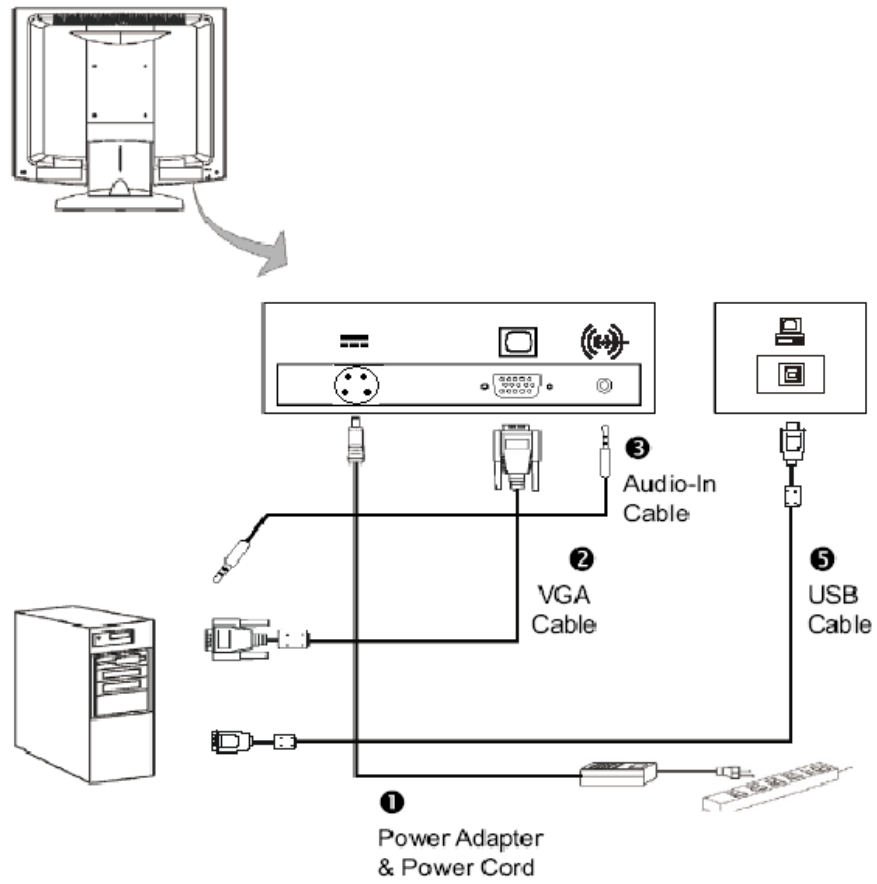
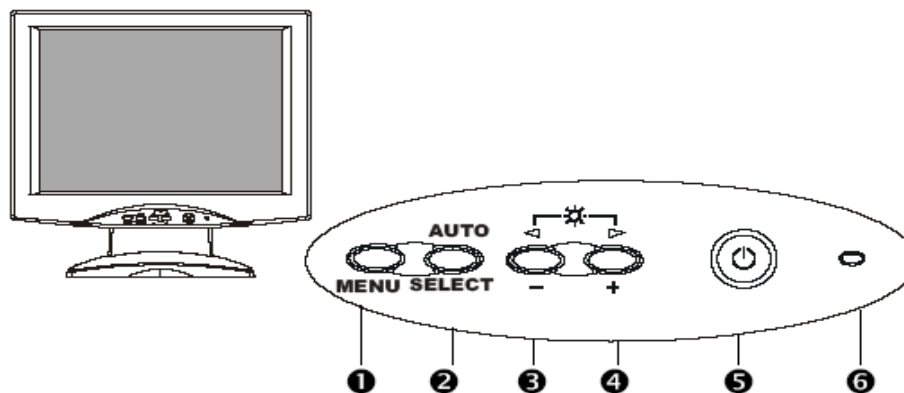

Figure 11.2



User Controls

Front Panel Controls



No / Icon	Control	Function
1 MENU	Menu button	Display the OSD menus
2 SELECT/AUTO	Select/Auto	Select – To select the adjustment items from OSD menus. Auto – To activate the “Auto Adjustment” function to obtain an optimum image.
3 ◀	Brightness Minus/Minus	1. Decreases the brightness of the display image. 2. Decreases value of the adjustment items.
4 ▶	Brightness Plus/Plus	1. Increases the brightness of the display image. 2. Increases value of the adjustment items.
5 ⏻	Power Switch	Switches on/off the power of the LCD display.
6	Power LED	1. Green indicates the display is turned on. 2. Amber indicates the display is in power-saving mode.

How to Use the OSD Menu

1. Press the "MENU" button to pop up the "on-screen menu" and to select among the four Main Menus.
2. Choose the adjustment items by pressing the "Select/Auto" button.
3. Adjust the value of the adjustment items by pressing the "◀" or "▶" button.
2. The OSD menu will automatically close, if you have left it idle for a pre-set time.
3. To disable the OSD menu buttons, please follow the instructions below:
(Please note: the monitor has to be ON with a valid signal present)
 - a. Press and hold the "-" and "Menu" key simultaneously for 4 seconds.
 - b. The wording "OSD Locked" will appear for 4 seconds on the monitor. This indicates that all the front buttons, with the exception of the power button, are now disabled.
4. To enable the OSD menu buttons, please follow the instructions below.
(Please note: the monitor has to be ON with a valid signal present)
 - a. Press and hold the "-" and "Menu" key simultaneously for 4 seconds.
 - b. The wording "OSD Unlocked" will appear for 4 seconds on the monitor. This indicates that all the front buttons are now enabled.

On-Screen Display Menus for the PT1510MX Product

Main Menu	Menu Level 2	Function Description	Remark
Brightness		Choose this function to adjust the brightness of the image.	Default 30
Contrast		Choose this function to adjust the contrast of the image.	Default 40
LCD Adjustment	Clock	Minimizes any vertical bars or stripes visible on the screen.	
	Phase	Minimizes any horizontal distortion and clears or sharpens the displayed characters.	
	H. Position	Changes the horizontal position of the image.	
	V. Position	Changes the vertical position of the image.	
Color Temperature		Opens the color temperature sub-menu where you can select the desired color temperature of the image. (SRGB / 9300K / 7200K / 6500K / 5000K / USER)	Default is 7200K
ECO mode		Enables or disables the power savings mode. (On/Off)	
Language		Opens the language sub-menu where you can select the desired language of the OSD.	Default English
Other Setup	Smooth	Adjusts the smoothness of the image.	Default 0
	OSD H. Position	Changes the horizontal position of the OSD.	Default 50
	OSD V. Position	Changes the vertical position of the OSD.	Default 50
	OSD Transparency	Changes the opaqueness of the OSD background.	Default 0
	OSD Time out	Adjusts the amount of time the OSD menu will be displayed for after inactivity.	Default 30
	Volume	Adjusts the sound volume.	Default 50
	Mode Message	Enables or disables the display of information.	
	Reset	Resets the display parameters back to its factory default settings.	
Exit		Exit the OSD menu.	

Appendix

Troubleshooting

If you are experiencing trouble with the LCD display, refer to the following. If the problem persists, please contact your local dealer or our service center.

Problem: No image appears on screen.

- ▶ Check that all the I/O and power connectors are correctly and well connected as described in the “Installation” section.
- ▶ Make sure the pins of the connectors are not crooked or broken.

Problem: Partial Image or incorrectly displayed the image.

- ▶ Check to see if the resolution of your computer is higher than that of the LCD display.
- ▶ Reconfigure the resolution of your computer to make it less than or equal to 1024 x 768.

Problem: Image has vertical flickering line bars.

- ▶ Use "Clock" to make an adjustment.
- ▶ Check and reconfigure the display mode of the vertical refresh rate of your graphic card to make it compatible with the LCD display.

Problem: Image is unstable and flickering

- ▶ Use "Phase" to make an adjustment.

Problem: Image is scrolling

- ▶ Check and make sure the VGA signal cable (or adapter) is securely connected.
- ▶ Check and reconfigure the display mode of the vertical refresh rate of your graphics card to make it compatible with the LCD Display.

Problem: Vague image (characters and graphics)

- ▶ Use "Clock" to make an adjustment. If this problem still exists, use “Phase” to make an adjustment.

Warning Signal

If you see warning messages on your LCD screen, this means that the LCD display cannot receive a clean signal from the computer graphics card.

There may be two sources for this problem. Please check the cable connections or contact Planar for more information.

▶ **No Signal**

This message means that the LCD Display has been powered on but it cannot receive any signal from the computer graphics card. Check all the power switches, power cables, and VGA signal cable.

▶ **Out of Range**

This message means that the signal of the computer graphic card is not compatible with the LCD display. When the signal is not included in the "Video Modes" list we have listed in the Appendices of this manual, the LCD display will display this message.

Product Dimensions

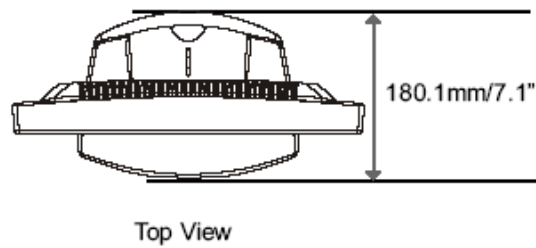
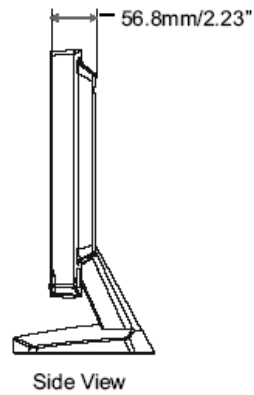
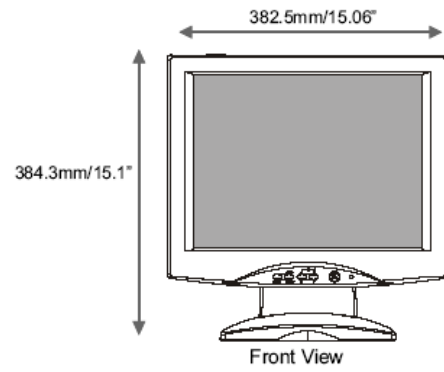

Compatibility Modes

Mode	Resolution	V. Frequency (Hz)	H. Frequency (kHz)
IBM VGA	640 x 350	70	31.5
IBM VGA	640 x 400	70	31.5
IBM VGA	720 x 400	70	31.5
IBM VGA	640 x 480	60	31.5
VESA VGA	640 x 480	72	37.9
VESA VGA	640 x 480	75	37.5
VESA SVGA	800 x 600	56	35.2
VESA SVGA	800 x 600	60	37.9
VESA SVGA	800 x 600	72	48.1
VESA SVGA	800 x 600	75	46.9
VESA XGA	1024 x 768	60	48.4
VESA XGA	1024 x 768	70	56.5
VESA XGA	1024 x 768	75	60.0
Apple Mac LC	640 x 480	67	34.9
Apple Mac II	640 x 480	67	35.0
Apple Mac	832 x 624	75	49.7
Apple Mac	1024 x 768	75	60.2

Touch Screen Driver Installation

The PT1510MX is available with both RS-232 and USB connections. The PT1510MX is Microsoft® Windows® HID (Human Interface Device) compatible if you use the **USB touch screen interface**. No additional software driver is required for general operation of the touch screen. A calibration tool can be installed for improved touch position accuracy. See “Optional Resistive Calibration Tool Install” section for more information.

The touch driver is located on the enclosed CD-ROM for these operating systems: Windows® VISTA, XP, 2000, ME, 98, NT4.0, CE, XP Embedded, Linux, Apple® Mac OS

Please note: Do not plug in both RS232 and USB cables. Doing so may cause a driver conflict, making your touch screen idle.

Driver Installation Process:

1. Before you start to install the touch driver, please be sure the USB or the RS-232 Serial cable is connected to the PC and LCD display.
2. Uninstall any touch screen driver that may be on your system.
3. Restart your computer.
4. Click on the appropriate link found on the CD-ROM.
5. Follow instructions as found below.
6. After installation is complete, click “Finish” to complete installation.

PT1510MX Optional Resistive Calibration Tool Install:

If you would like to use the Optional Resistive Calibration Tool, follow the instructions below:

1. Open the CD-Rom.
2. Select the Monitor Size and then Model Name
3. Click on the “Load Utility” button that appears to the right of the Model Name.
4. The HID calibration tool will automatically open. From here the user can choose to do the following:
 - a. 4 Points Calibration
 - b. 9 Points Linearization
 - c. 25 Points Linearization
 - d. Clear
 - e. Draw Test
 - f. Advanced. In the Advanced settings area the user may do the following:
 - i. Adjust the Double Click Area
 - ii. Enable auto right click and adjust the auto right click time
 - iii. Choose to be either in the HID Mouse Mode or HID Digitizer Mode (Windows® Vista only)
 - iv. Simply click the “Apply” button once the settings are finalized.

If you are using a PC running Windows® Vista, XP or 2000 operating system, follow the instructions below.

Using the RS232 connection:

1. Be sure that RS232 cable is connected from the computer.
2. Power on the computer.
3. Load the touch screen driver CD.
4. Follow the step-by-step instructions as shown on pop-up windows.

Using the USB connection:

1. Be sure that USB cable is connected from the computer.
2. Power on the computer.
3. Load the touch screen driver CD.
4. Follow the step-by-step instructions as shown on pop-up windows.

If you are using a PC running Windows® XP Embedded, follow the instructions below:

1. Power on the computer.
2. Make sure that the RS232 or USB cable is connected to the computer.
3. Be sure that your EWF (Enhanced Write Filter) is **disabled**. If your EWF is enabled, please disable the EWF by using the EWF Manager command.
4. Once the EWF is disabled click on the XP driver on the CD and follow the step-by-step instructions as shown on the pop-up windows.

Product Registration and Technical Support

Register Your Planar Products Today

Thank you for choosing Planar. To assure you receive all the benefits of your Planar product and services, register your Planar product today. Visit our website at http://www.planar.com/support/product_registration.html.

Cables, Replacement Lamps, Accessories

To find cables, replacement lamps and accessories for your Planar projector, LCD monitor, touch screen or other Planar products visit our online store at www.PlanarOnline.com or find other stores who carry Planar products at <http://www.planar.com/howtobuy>.

Technical Support

Visit Planar at <http://www.planar.com/support> for product registration, operations manuals, touch screen drivers, warranty information and access to Planar's Technical Library for online troubleshooting.

Online chat service is available Monday through Friday from 12am to 6pm Pacific Time.

To speak with Planar Customer Support please have you model and serial number available and dial:

Planar Support

Tel: 1-866-PLANAR1 (866-752-6271) or +1 503-748-5799 outside the US.

Hours: 24 hours a day, 7 days a week.

Toll or long distance charges may apply.



PT1510MX

触摸屏液晶显示器

用户指南

www.planar.com

本文档中包含的信息如有变更，恕不另行通知。

本文档包含由版权保护的专属信息。保留所有权利。未经事先书面许可，不得复制、翻译本文档的内容或将其存储在检索系统中，或者以任何形式（电子、机械、影印、记录或其它方式）进行传输。

Windows是Microsoft, Inc.的注册商标。

其它品牌或产品名称均属各自拥有人所有。

重要资源回收说明：



本产品内的灯泡含有汞元素。本产品可能包含其它电子废弃有害物质，如果处理不当，则会造成危害。请按照当地、州省或联邦法律进行回收处理。有关详情，请联系电子工业联盟：

WWW.EIAE.ORG。有关灯泡的具体处理信息，请查阅
WWW.LAMPRECYCLE.ORG。

目录

使用须知

使用前注意事项.....	2
--------------	---

介绍

Planar PT1510MX简介.....	3
------------------------	---

PT1510MX触摸屏.....	4
------------------	---

组件概览.....	5
-----------	---

安装

产品概述.....	6
-----------	---

显示器的VESA安装.....	9
-----------------	---

开始安装.....	10
-----------	----

用户控制

前面板控制.....	14
------------	----

如何使用OSD菜单.....	15
----------------	----

PT1510MX产品的屏幕显示菜单.....	16
------------------------	----

附录

故障排除.....	17
-----------	----

警告信号.....	18
-----------	----

产品尺寸.....	19
-----------	----

兼容性模式.....	20
------------	----

触摸屏驱动程序安装.....	21
产品注册和技术支持.....	24

使用须知

 **警告**-为了避免火灾或者触电危险,请勿使本产品遭受雨淋或受潮。

 **警告**-请勿打开或拆解本产品,以免遭到电击。

注意事项

遵照本用户手册中建议的所有警告、注意事项和维护步骤以延长产品的寿命。

应做：

- 清洁之前关闭设备。
- 可使用干净软布,沾取适度窗户玻璃清洁剂或水与异丙醇50/50混合物,清洁触摸屏。
- 使用沾有适度清洁剂的软布清洁显示器外壳。
- 只使用随显示器附带的高质量、经过安全认证的交流/直流适配器。
- 如果长时间不使用设备,请从AC电源插座上拔下电源插头。

禁止：

- 禁止**用坚硬尖锐物件接触LCD显示屏表面。
- 禁止**使用研磨剂、蜡剂或溶剂进行清洁。
- 禁止**在以下条件下使用设备：
 - 高温、严寒或非常潮湿的环境。
 - 容易染尘沾污的环境。。

- 产生强磁场的电器的附近。
- 阳光直射。

介绍

Planar PT1510MX简介

PT1510MX为 15"平板显示器采用有源矩阵、薄膜晶体管 (TFT) 液晶显示屏 (LCD)。

功能特点：

- 直接模拟信号输入
- 有源矩阵TFT LCD技术
- 1024x768 XGA分辨率
- 15"对角屏幕尺寸
- 31.5 ~ 60 kHz水平扫描
- 56 ~ 75 Hz高刷新频率
- 自动调整功能
- 多语言OSD用户控制
- VESA DPMS节能
- Kensington防盗锁槽
- 多媒体用途的内置扬声器
- 75 mm VESA安装

- 可拆卸底座，可实现灵活的安装解决方案
- 5线电阻式触摸屏，配有双RS-232串行/USB控制器
- 内置扬声器 – 1W/声道

PT1510MX触摸屏

- 模拟式5线电阻式触摸屏，可以用手指和光笔进行输入
- 表面：防眩光处理
- 接口：双RS-232串行/USB控制器
- 耐久性：单点触摸3500万次
- 表面硬度：2H MIN (JIS K 5400上提供)
- 操纵力:0.10 ~ 1.96N (使用3 mm半径和60硬度的硅尖笔时10g ~ 200g。)
- 透射率：76% (典型值)
- 驱动程序：支持 Windows® VISTA, XP, 2000, ME, 98, NT4.0, CE, XP Embedded, Linux, Apple® Mac OS

组件概览



液晶显示器

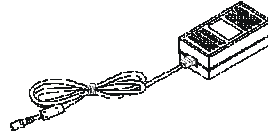

电源适配器

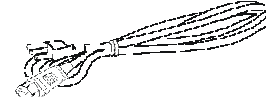

电源线

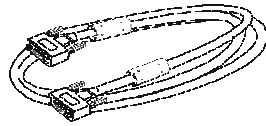

VGA信号线



音频输入线



USB线

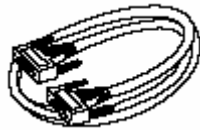

RS-232线



快速入门卡



触摸屏驱动程序
安装光盘



用户指南

安装

产品概述

◆ 正视图

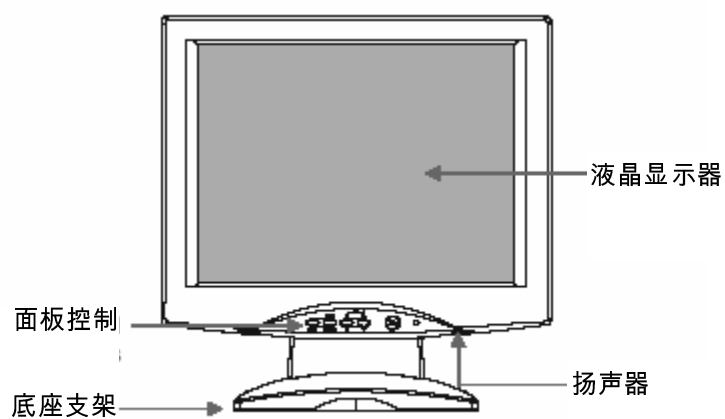

◆ 后视图

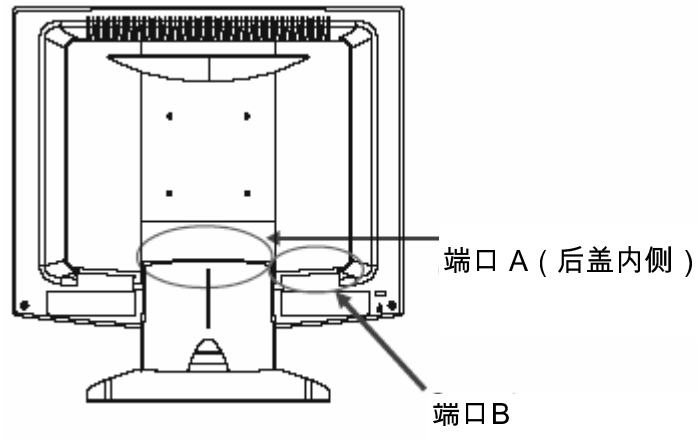

◆ 端口A

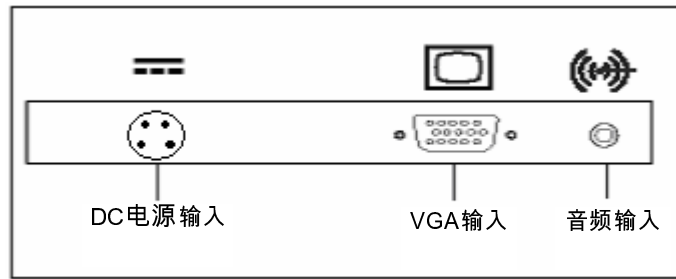

◆ 端口B

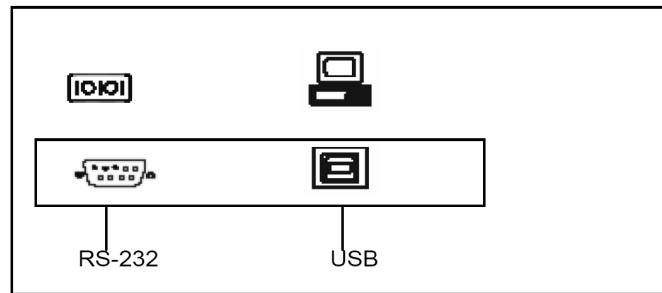

◆ Kensington防盗锁槽

可以用Kensington防盗锁将显示器固定到桌子或其它固定物体上。
Kensington防盗锁没有随产品附带。

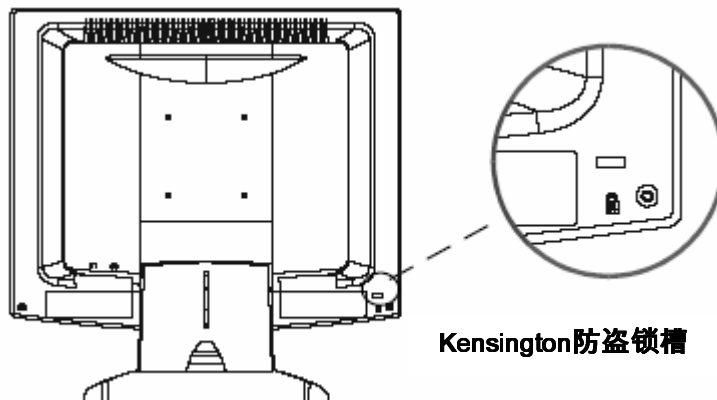

显示器的VESA安装

本显示器符合VESA平板显示器自行安装界面标准，该标准定义了平板显示器的自行安装界面，以及平板显示器安装设备(如墙壁和桌台臂杆)的相应标准。VESA安装接口位于显示器的背后。

要将显示器安装到活动臂杆或其它安装固定物件上，请遵照要使用的安装固定物件附带的说明书。

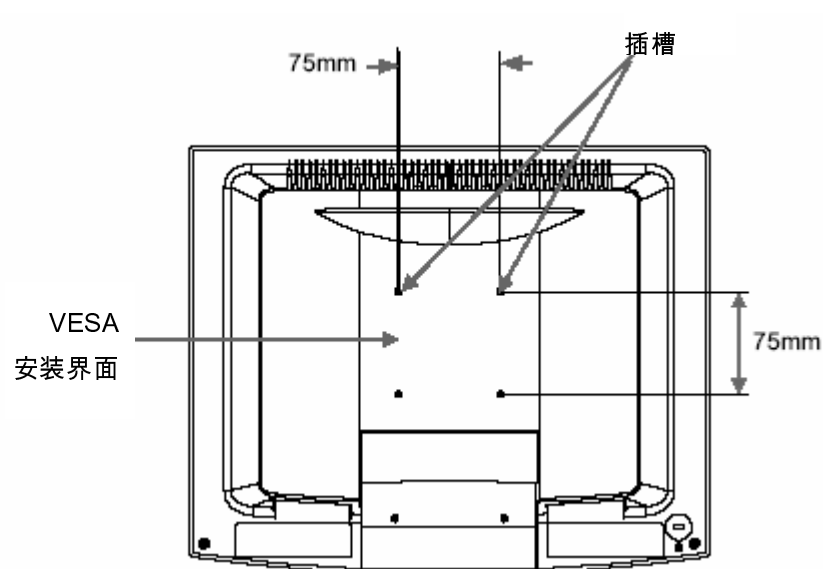

警告！

请选择正确的螺丝！

后盖表面与螺丝孔底部之间的距离为8 mm。请使用直径最长为8 mm的M4螺丝。

开始安装

◆ 拆卸后盖

请按照以下说明拆卸液晶显示器的后盖，以便您可以将线缆连接到“端口B”。

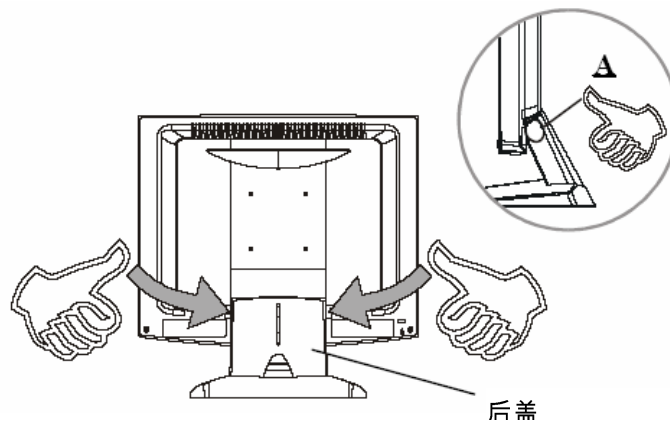

1. 要卸下后盖，请按照图A箭头所示，用双手拇指按下。在拉住后盖的同时，沿着边缘用力按，即会卸下后盖。
2. 按照11页（图11.1）的说明将线缆连接到“端口B”。
3. 用力按下，直到弹片卡扣入位，以便将后盖固定到液晶显示器。您也可以使用理线槽依序排列线缆。

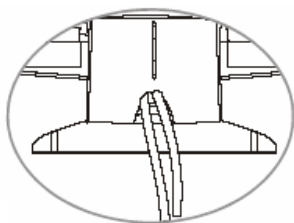

包含有理线槽

 **注意！**

您可以平放液晶显示器，以便它可以连接线缆。确保将它放在一个平整的表面上，以免刮碰造成液晶显示器。

◆ 连接显示器 (图11.1、 11.2)

要安装设置显示器，请参照下面的图示和步骤。

1. 确保所有设备已关闭。
2. 将DC电源线连接到显示器上的电源接口；将AC电源线的一头插接到电源适配器，将另一头插接到电源插座 (11.1 ❶)。
3. 将VGA信号线从显示器的VGA输入接口连接到主机的15针接口，并拧紧螺丝(11.1 ❷)。
4. 将音频输入线从显示器的音频输入端口连接到计算机的音频输出端口(11.1 ❸)。
5. 配置触摸屏。参照第21页“触摸屏驱动程序安装”部分。
6. 触摸屏配置完成后，显示器即可使用。



为保证液晶显示器有效配合计算机工作，请配置图形卡的显示模式，分辨率应小于或等于1280 x 1024，并确保显示模式的计时兼容本液晶显示器。

我们已经在附录中列出了本液晶显示器的兼容“视频模式”，供您参考。

图11.1



图11.2



用户控制

前面板控制

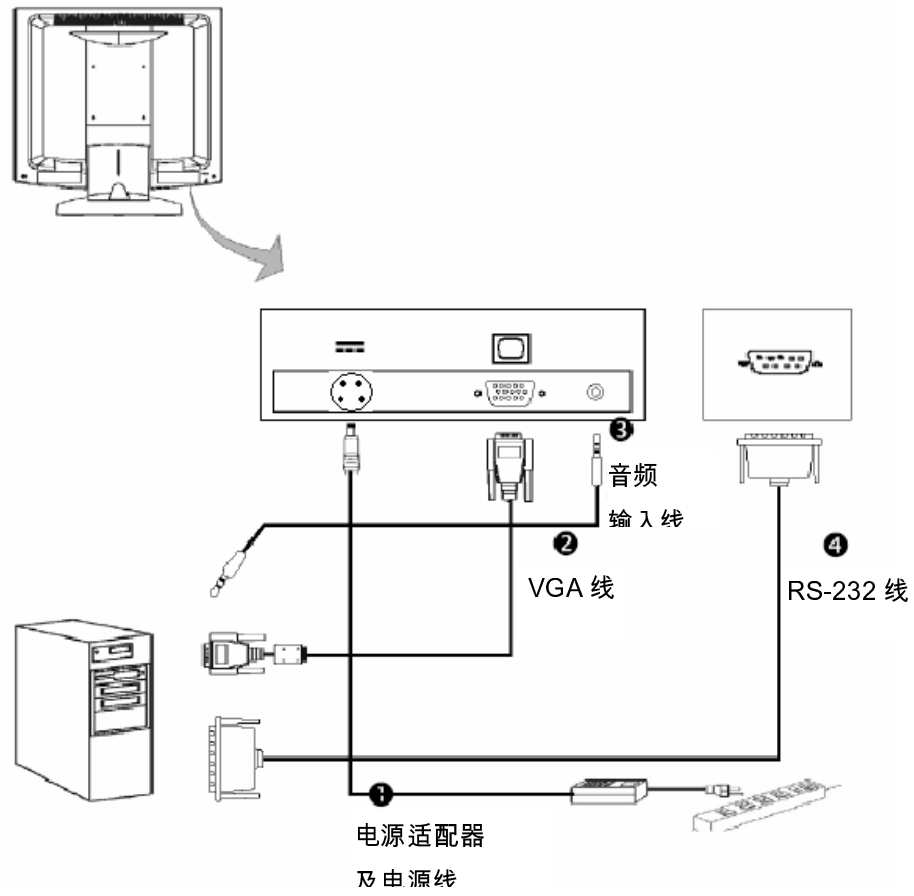
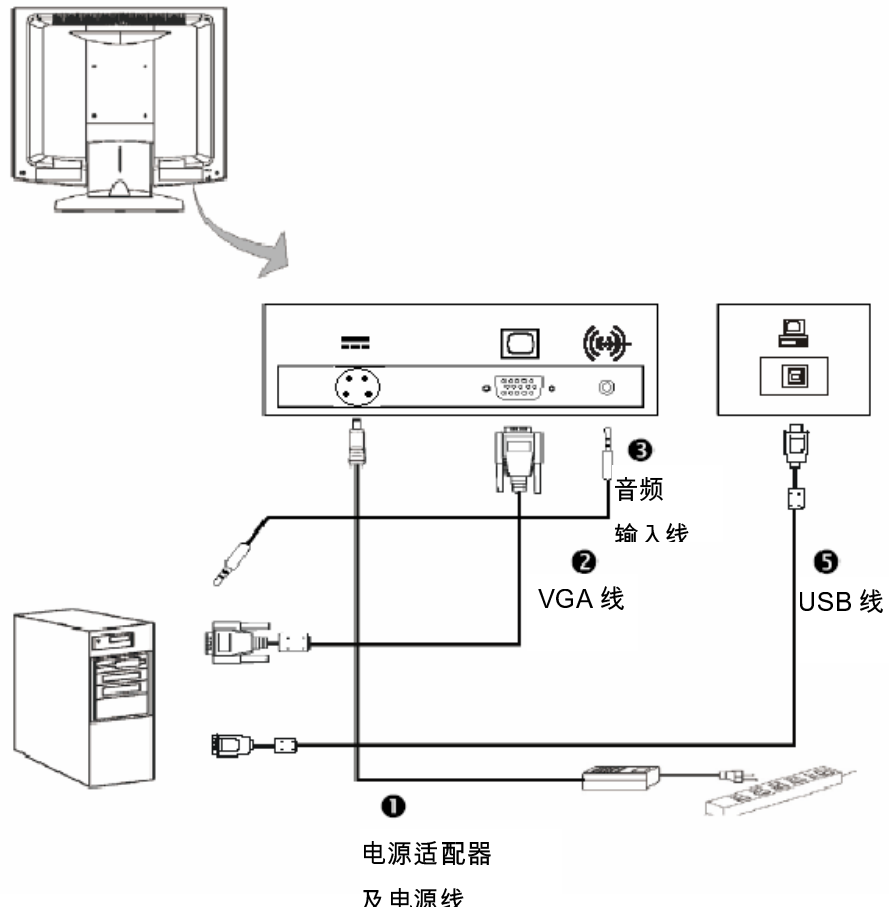
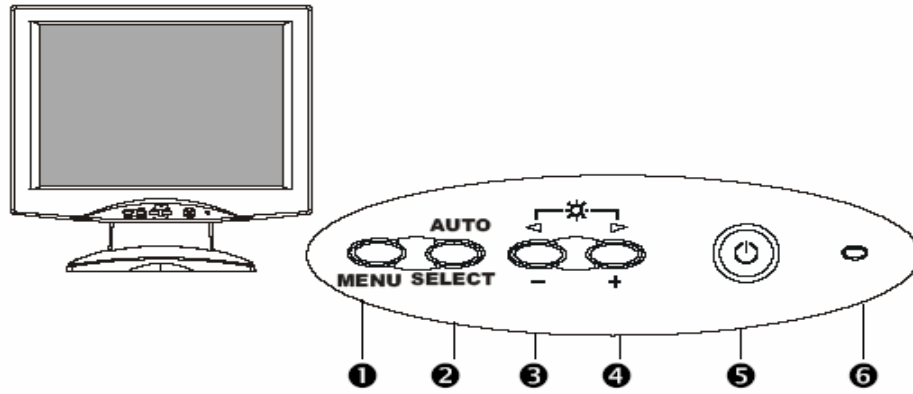

编号/图标	控制	功能
① MENU	菜单按钮	显示OSD菜单。
② SELECT/AUTO	选择/自动	选择 — 从OSD菜单中选择调整项目。 自动 — 启动“自动调整”功能以获得最佳图像。
③ ◀	亮度 减号/减号	1. 减小显示图像的亮度。 2. 减小调整项目的值。
④ ▶	亮度 加号/加号	1. 增加显示图像的亮度。 2. 增加调整项目的值。
⑤ ⏻	电源开关	打开/关闭液晶显示器的电源。
⑥	电源LED	1. 绿色表示显示器已开机。 2. 黄色表示显示器处于节能模式中。

如何使用OSD菜单

1. 按“MENU”按钮弹出“on-screen menu”，然后在四个主菜单中选择。
2. 按“Select/Auto”按钮选择调整项目。
3. 按“◀”或“▶”按钮调整项目的值。
4. 如果闲置超过预设时间，则OSD菜单会自动关闭。

5. 要禁用OSD菜单按钮，请按照以下说明操作：

(**请注意**：显示器必须为开机，并且预设了有效信号。)

- a. 同时按住“-”和“Menu”键4秒。
- b. “OSD Locked” (OSD已锁定) 信息会在显示器上显示4秒。
这表示除电源按钮之外，所有前面按钮都被禁用。

6. 要启用OSD菜单按钮，请按照以下说明操作。

(**请注意**：显示器必须为开机，并且预设了有效信号。)

- a. 同时按住“-”和“Menu”键4秒。
- b. “OSD Unlocked” (OSD已解锁) 信息会在显示器上显示4秒。这表示所有前面按钮都被启用。

PT1510MX产品的屏幕显示菜单

主菜单	2级菜单	功能说明	备注
Brightness(亮度)		选择此功能可以调整图像的亮度。	默认值为30
Contrast(对比度)		选择此功能可以调整图像的对比度。	默认值为40
LCD Adjustment (LCD调整)	Clock(时脉)	最小化屏幕上出现的竖条。	
	Phase(相位)	最小化水平扭曲,并使显示的字符更清晰。	
	H. Position (水平位置)	更改图像的水平位置。	
	V. Position (垂直位置)	更改图像的垂直位置。	
	Color Temperature (色温)	打开色温子菜单,在这里您可以选择所需的图像色温。 (SRGB/9300K/7200K/6500K/5000K/ USER)	默认值为7200K
ECO mode (ECO 模式)		启用或禁用节能模式。(开/关)	
Language(语言)		打开语言子菜单,在这里您可以选择所需的OSD语言。	默认值为English
Other Setup (其它设置)	Smooth (平滑度)	调整图像的平滑度。	默认值为0
	OSD H. Position (OSD水平位置)	更改OSD的水平位置。	默认值为50
	OSD V.Position (OSD垂直位置)	更改OSD的垂直位置。	默认值为50
	OSD Transparency (OSD透明度)	更改OSD背景的透明度。	默认值为0
	OSD Time out OSD 超时	调整不活动后,OSD菜单显示的时间长短。	默认值为30
	Volume(音量)	调整音量。	默认值为50
	Mode Message (模式信息)	启用或禁用信息显示。	
	Reset(恢复设置)	将显示器参数恢复到出厂默认设置。	

Exit(結束)		退出OSD菜单。	
----------	--	----------	--

附录

故障排除

如果液晶显示器出现故障，请查阅以下内容。如果问题仍未解决，请联系当地经销商或我们的服务中心。

问题：屏幕上没有图像。

- ▶ 检查所有I/O和电源接口均已如“安装”部分中所述正确、完好地连接。
- ▶ 确保接口插针没有弯曲或折断。

问题：只显示部分图像或图像显示不正确。

- ▶ 检查一下计算机的分辨率是否高出液晶显示器的分辨率。
- ▶ 重新配置计算机的分辨率，使其小于或等于1024 x 768。

问题：图像有闪烁的竖条。

- ▶ 使用“Clock”进行调整。
- ▶ 检查并重新配置图形卡垂直刷新率的显示模式，使其符合液晶显示器的显示范围。

问题：图像闪烁、不稳定

- ▶ 使用“Phase”进行调整。

问题：图像滚动

- ▶ 检查并确保VGA信号线（或适配器）已牢固连接。
- ▶ 检查并重新配置图形卡垂直刷新率的显示模式，使其符合液晶显示器的显示范围。

问题：图像（字符和图形）不清楚

- ▶ 使用“Clock”进行调整。如果问题仍在存在，请使用“Phase”进行调整。

警告信号

如果您在液晶显示器屏幕上看到警告信息，则表示液晶显示器无法从计算机图形卡接收完好的信号。

出现此问题可能有两个原因。请检查线缆连接或联系Planar了解更多信息。

▶ No Signal (无信号)

此信息表示液晶显示器已打开，但无法从计算机图形卡接收任何信号。请检查所有电源开关、电源线和VGA信号线。

▶ Out of Range (超出范围)

此信息表示计算机图形卡的信号与液晶显示器不兼容。当信号没有包括我们在本手册“附录”中所列的“Video Modes(视频模式)”列表中时，液晶显示器将显示此信息。

产品尺寸

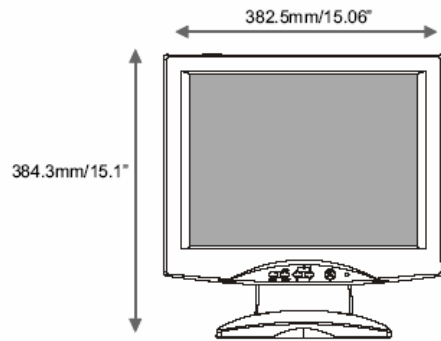

正视图

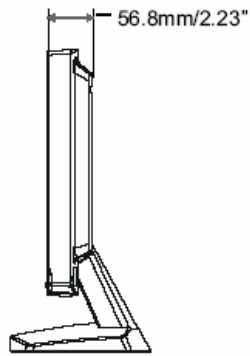

侧视图

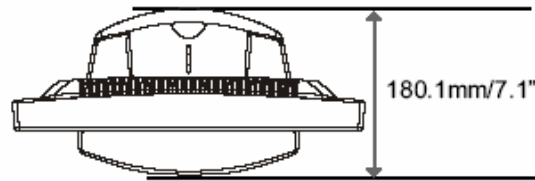

顶视图

兼容性模式

模式	分辨率	垂直频率 (Hz)	水平频率 (kHz)
IBM VGA	640 x 350	70	31.5
IBM VGA	640 x 400	70	31.5
IBM VGA	720 x 400	70	31.5
IBM VGA	640 x 480	60	31.5
VESA VGA	640 x 480	72	37.9
VESA VGA	640 x 480	75	37.5
VESA SVGA	800 x 600	56	35.2
VESA SVGA	800 x 600	60	37.9
VESA SVGA	800 x 600	72	48.1
VESA SVGA	800 x 600	75	46.9
VESA XGA	1024 x 768	60	48.4
VESA XGA	1024 x 768	70	56.5
VESA XGA	1024 x 768	75	60.0
Apple Mac LC	640 x 480	67	34.9
Apple Mac II	640 x 480	67	35.0
Apple Mac	832 x 624	75	49.7
Apple Mac	1024 x 768	75	60.2

触摸屏驱动程序安装

PT1510MX带有RS-232和USB接口。使用USB触摸屏接口时，PT1510MX还可与Microsoft® Windows® HID（人机接口设备）兼容。触摸屏常规运行时，无需额外的软件驱动程序。可安装一个校准工具，提高触点定位的精度。欲了解更多信息，敬请查阅“电阻式校准工具的安装选项”章节。

触摸屏驱动程序位于所附带的光盘上，可用于以下操作系

统：Windows® VISTA, XP, 2000, ME, 98, NT4.0, CE,

XP Embedded, Linux, Apple® Mac OS。

请注意：请勿同时插入RS232和USB连接线。因为这样会引起驱动程序冲突，使触摸屏无法正常工作。

驱动程序安装过程：

1. 安装触摸屏驱动程序之前，请确保USB或RS232串行连接线与PC和LCD显示器相连。
2. 卸载系统已有的任何触摸屏驱动程序。
3. 重新启动计算机。
4. 单击CD-ROM上的正确链接。
5. 按照以下步骤进行操作。
6. 安装结束后，单击“Finish”，完成安装。

PT1510MX电阻式校准工具安装选项：

如需使用电阻式校准工具安装选项，请参照以下说明：

1. 打开CD-Rom。
2. 选择监视器尺寸和型号
3. 点击型号名称右侧出现的“Load Utility”按钮
4. HID校准工具可自动开启。至此，用户可选择执行以下操作：
 - a. 4点校准法
 - b. 9点线性法
 - c. 25点线性法
 - d. 清除
 - e. 绘图测试
 - f. 高级。在高级设置区域，用户可进行以下操作：
 - i. 调整双击区域的大小
 - ii. 支持自动右键点击功能使能，并调整自动右键点击的时间
 - iii. 选择HID鼠标模式或HID数字转换器模式（仅限于Windows® Vista）
 - iv. 单击摺“apply”键，完成所有设置。”

若您PC安装的操作系统为Windows® Vista, XP 或 2000，请按照以下说明操作：

采用RS232连接方式：

1. 确保 RS232 连接线与计算机相连
2. 打开计算机。
3. 加载触摸屏驱动程序 CD。
4. 根据弹出窗口中的说明，逐步执行。

采用 USB 连接方式：

1. 确保 USB 连接线与计算机相连
2. 打开计算机。
3. 加载触摸屏驱动程序 CD。
4. 根据弹出窗口中的说明，逐步执行。

若您的 PC 安装的操作系统为嵌入式 Windows® XP，请按照以下说明操作：

1. 打开计算机。
2. 确保 RS232 或 USB 连接线与计算机相连。
3. 确定您的保 EWF (增强型写过滤器) 功能不可用。 若您的 EWF 功能状态为可用，请通过 EWF 管理器命令关闭该功能。
4. 关闭 EWF 功能后，单击 CD 上的 XP 驱动程序，并根据弹出窗口中的说明逐步执行。

产品注册和技术支持

立即注册您的 Planar 产品

感谢您选购 Planar 产品。为确保您能够全面体验 Planar 产品的优点和周到的服务，请立即注册您的 Planar 产品。请访问我们的网站：

http://www.planar.com/support/product_registration.html.

缆线、备用灯及其他附件

如需购买用于 Planar 投影仪、液晶显示器、触摸屏或其他 Planar 产品的缆线、备用灯和各种附件，请访问我们的网上商店：www.PlanarOnline.com，或者通过访问 <http://www.planar.com/howtobuy>，了解其他出售 Planar 产品的商店。

技术支持

关于产品注册、操作手册、触摸屏驱动程序和保证信息，请访问 Planar 的网站 <http://www.planar.com/support>，您也可访问 Planar 的技术数据库，以实现在线排除故障。

在线咨询时间：周一至周五，12am 至 6pm (太平洋时间)

如需联系 Planar 客户支持部门，请确定您的产品型号和序列号，并拨打：

Planar 支持部门

电话: 1-866-PLANAR1 (866-752-6271) 或 +1 503-748-5799(美国以外)。

服务时间：24×7 全天候服务

客户可能需要支付长途电话费用。

产品中有毒有害物质或元素的名称及含量

部件名称	有毒有害物质或元素					
	铅(Pb)	汞(Hg)	镉(Cd)	六价铬 (Cr(VI))	多溴联苯 (PBB)	多溴二苯 醚 (PBDE)
塑胶壳	○	○	○	○	○	○
印刷电路(含零组件)	X	○	○	○	○	○
电缆/连接器	X	○	○	○	○	○
液晶显示屏	X	○	○	○	○	○
背光灯管部件	○	X	○	○	○	○
电源适配器	X	○	○	○	○	○
电源线/信号线	X	○	○	○	○	○
机械部件-金属件	X	○	○	○	○	○
机械部件-其它	○	○	○	○	○	○
软件(CD 等)	○	○	○	○	○	○

○:表示该有毒有害物质在该部件所有均质材料中的含量均在 SJ/T 11363-2006 标准规定的限量要求以下。
X:表示该有毒有害物质至少在该部件的某一均质材料中的含量超出 SJ/T 11363-2006 标准规定的限量要求。

液晶监视器/液晶显示器

在中国大陆销售的相应电子产品 (EIP) 都必须遵照中

国大陆《电子信息产品污染控制标识要求》标准贴上环

保佳田期限(FPIID)标签 本产品所采用的 FPIID 标签

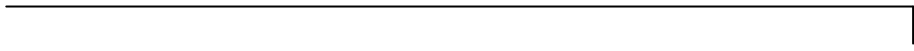

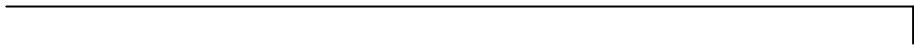

Planar Systems, Inc.

Customer Service

24x7 Online Technical Support: <http://www.planar.com/support>

1195 NW Compton Drive

Beaverton, OR 97006-1992

Tel: 1-866-PLANAR1 (866-752-6271) or +1 503-748-5799 outside the United States.

Hours: 24 hours a day, 7 days a week

© 2009 **Planar Systems, Inc.** 4/09 Planar is a registered trademark of Planar Systems, Inc.

Other brands and names are the property of their respective owners.

Technical information in this document is subject to change without notice.

Planar Systems, Inc.

客户服务

24x7 在线技术支持 : <http://www.planar.com/support>

1195 NW Compton Drive

Beaverton, OR 97006-1992

电话 : 1-866-PLANAR1 (866-752-6271)或+1 503-748-5799 (美国以外) 。

服务时间 : 24x7全天候服务

© 2009 **Planar Systems, Inc.** 4/09 Planar是Planar System, Inc.的注册商标。

其它品牌或名称均属各自拥有人所有。

本文档中的技术信息如有变更 , 恕不另行通知。

P/N:36.57724G003 Rev.A

020-0454-00C